

# DIAL CODE SERIES

OWNERS MANUAL

Telephone entry systems with two line large LC or VF displays

with  
**BUILT-IN**  
surge suppression



VISIT US ON THE WEB  
[www.eliteentryphone.com](http://www.eliteentryphone.com)



# TABLE OF CONTENTS

Product Overview ..... 2

Resident Use ..... 3-4

Screen Saver Mode (VF Only) ..... 4

**LC** Entry Phone Features Inside / Outside ..... 5-6

**VF** Entry Phone Features Inside / Outside ..... 7-8

Entry Phone Features (Processor) ..... 9

**LC** Mounting Installation ..... 10

**VF** Mounting Installation ..... 11

Description of Surge Suppression Terminal Board ..... 12

Grounding the Unit ..... 13

Earth Ground Rod Installation ..... 14

Basic Wiring Diagram ..... 15

Postal Lock Installation ..... 16

RS-485 Connections ..... 17-19

Memory Card Installation ..... 20

Viewing Software Version ..... 20

Warning and Precautions ..... 21

Programming the Processor ..... 22

Selecting Program Mode ..... 23

Resident Information ..... 24

Transmitter / Card Programming ..... 25

Area Codes ..... 26

Utility Codes ..... 27

Password ..... 28

Clock / Timer ..... 29-31

Strike Time ..... 32

Talk Time ..... 32

Greeting ..... 33

Volume Adjustment ..... 33

Back-Up Memory ..... 34

Error Messages ..... 35

**LC** Illustration and Parts List ..... 36

**VF** Illustration and Parts List ..... 37

Approvals ..... 38



© 1997-2003 by Elite Entry Phone - All Rights Reserved. No part of this manual may be reproduced in any means graphic, electronic or mechanical, including photocopying without the expressed written permission of the publisher. Materials, components and specifications are subject to change without notice.

**LC/VF manual**  
**Version 3.0**

**⚠ To be installed by Qualified Dealers ONLY!**

# PRODUCT OVERVIEW

## STANDARD FEATURES

- Two line LC or VF Directory.
  - Names listed in Directory in alphabetical order.
- Memory capacity: 25, 50, 150, 250, 500, 1000 names.
- User-friendly programmability via built-in alpha-numeric keyboard eliminates the need for user's manual.
- Four character alpha-numeric password required to enter programming mode.
- Programmable Utility keycodes for keyless entry.
  - 60 Utility keycodes available per system.
  - Time zones associated with Utility keycodes.
- Programmable real-time clock with leap year & daylight savings compensation.
- 2 programmable 7-day timers for door and gate control.
- Programmable talk time.
- Touch-tones through microphone are ignored by system.
- System mutes tones in speaker during dialing.
- Postal lock capability with programmable strike time.
- Surge protection;
  - 6000V, 3000A
  - Power input port
  - Telephone line port
  - RS-485 ports
  - Relay ports
  - Input port
  - Immune to 25,000V electrostatic discharge.
- Two output relays with independent strike times.
- Relay output for VCR time lapse recorder to record 5 seconds per transaction.
- Power failure backups:
  - Battery backup for complete function for 5 hrs.
  - Battery enables dial out, program, & display.
  - Non-Volatile removable SRAM memory has unlimited write cycles (unlike EEPROM).
  - Non-Volatile Real Time Clock/Calendar.
- High quality voice communication system with background noise filtering.
- Voice messages (digital) to help & guide user.
- Volume control via software.
- Non-Volatile PCMCIA memory card
- Two (2) slots for PCMCIA memory cards.
- Double box with built-in full keyboard for data processing.
- By pressing '9' for gate or '5' for door, communication is not lost. Talk time is extended to avoid unpleasant cutoff between visitor and resident.
- Both DTMF tone and rotary dial detection.
- Programmable via modem (optional).
- FCC part 68 ,15 & Canadian DOC approval
- ETL approved UL 294, UL 1950

## SPECIFICATIONS

- Construction: Front and Back Panel: 16 gauge stainless steel. Processor Containment Box: Gold/zinc plated, powder coated aluminum (weather resistant finish)
- Entire system is rain resistant.
- Power Input: 12 VAC, 40VA UL listed transformer(provided).
- Operating Environment:
  - Temperature: -40 F to +185 F. (Heater kit available at additional cost.)
  - Relative Humidity: 5% - 95% non-condensing.
- Dimensions: 11 1/4" W X 16 7/16" H X 4 1/8" D
- Shipping Weight: Approximately 25 lbs.

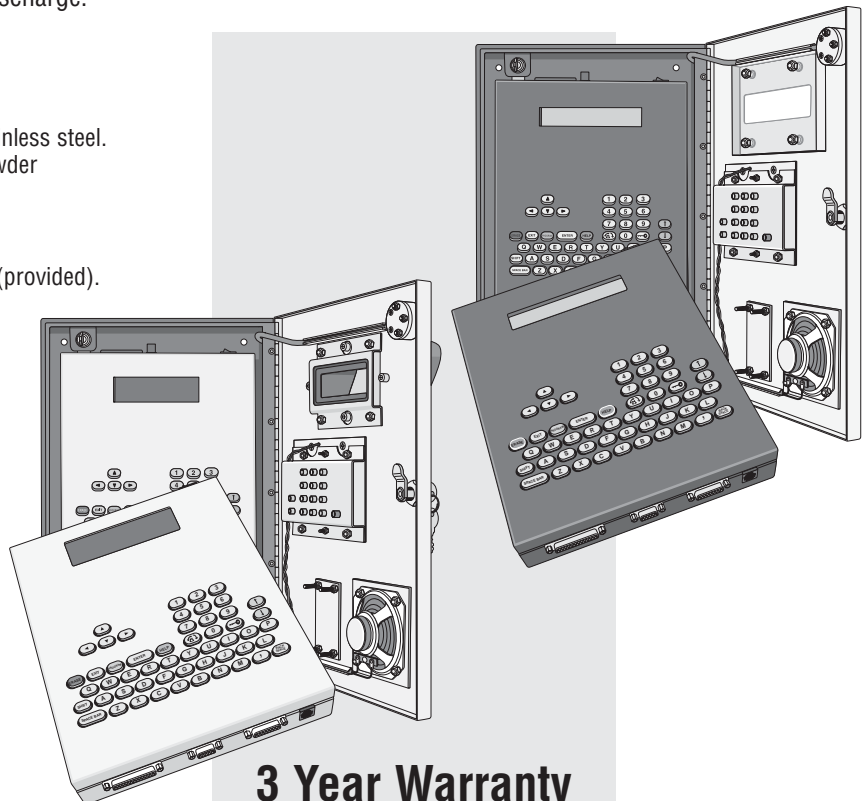

**3 Year Warranty**  
Factory to Dealer

# RESIDENTS USE

Welcome To  
Elite Entry Phone

(fig a.)

Use ↓ ↑ Keys  
To View Directory

(fig b.)

When operating, the Entry Phone System will alternate between the “Welcome” screen (fig a.) and the “View Directory” screen (fig b.).

Use the keys to scroll up and down through the names listed in the Entry Phone’s electronic directory as shown in (fig c.) The names are listed in alphabetical order by last name.

Fairbanks, George  
CODE: 012

(fig c.)

When the desired name is found, enter the corresponding 3-digit code. The system will dial the number assigned to the tenant code entered. (fig d.) After connecting, the screen will display the talk time as shown in (fig e.) If the resident wants to allow access to the visitor, they simply press (or dial) “9” for vehicular gate entrances, or “5” for door or pedestrian gate. If the resident wants to deny access, they simply hang up the phone.

Fairbanks, George  
DIALING! CODE: 012

(fig d.)

TIME TO TALK> 17 SEC  
██

(fig e.)

## Entry 1 — Vehicular Gate

By pressing or dialing the number “9” on their digital or rotary phone,

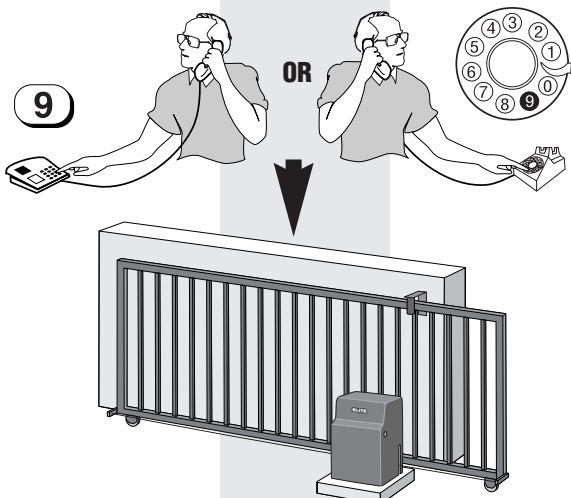

The resident will open the vehicular entrance gate.

## Entry 2 — Door or Pedestrian Gate

By pressing or dialing the number “5” on their digital or rotary phone,

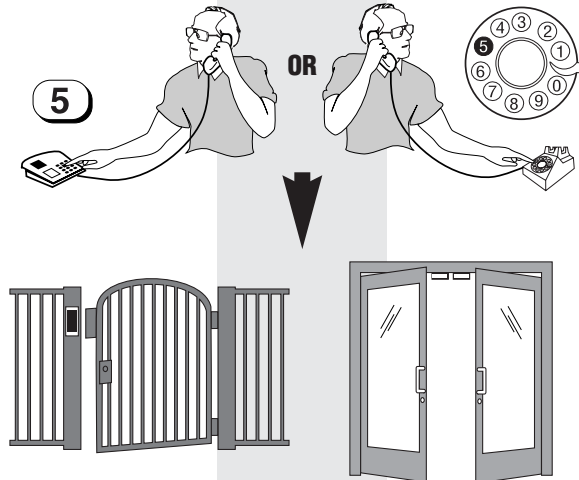

The resident will open the door or pedestrian gate.

# RESIDENT USE

## USING KEYCODES AND UTILITY CODES (ACTIVE ENTRY 1 ONLY)

### RESIDENT 6-DIGIT KEYCODES

Residents are assigned a 6-digit, personalized keycode for accessing the facility. To use the keycode assigned, the resident must first push the  key once and enter their keycode. The screen will display “**Access Granted**” (*fig a.*) and access will be allowed. If an incorrect keycode is entered, the system will inform the user of the invalid entry (*fig b.*) The resident can then re-enter their keycode.



(*fig a.*)



(*fig b.*)

**EXAMPLE - KEY CODE 002543** =       

### INDIVIDUAL UTILITY CODES

All systems, no matter what the memory capacity, are equipped with 60 different Utility codes. To access the facility within the time zone set, the Utility Company must first press the  key **TWICE** and then enter their 4-digit code. If it is within the programmed time zone for entry, the screen will display “**Access Granted**” (*fig c.*) and access will be allowed. If, however, it is not within the time zone for entry, the display will inform the user and access will not be allowed (*fig d.*)



(*fig c.*)



(*fig d.*)

**EXAMPLE - UTILITY CODE 8716** =      

## SCREEN SAVER MODE (VF ONLY)

If the VF Dial Code System is inactive for 15 seconds it will go into sleep mode. The screen will continue to display the scrolling message “**Press Any Key**” until a key is pressed (*fig e.*) The Screen saver mode is not available while in program mode.



(*fig e.*)

# LC ENTRY PHONE FEATURES (INSIDE)

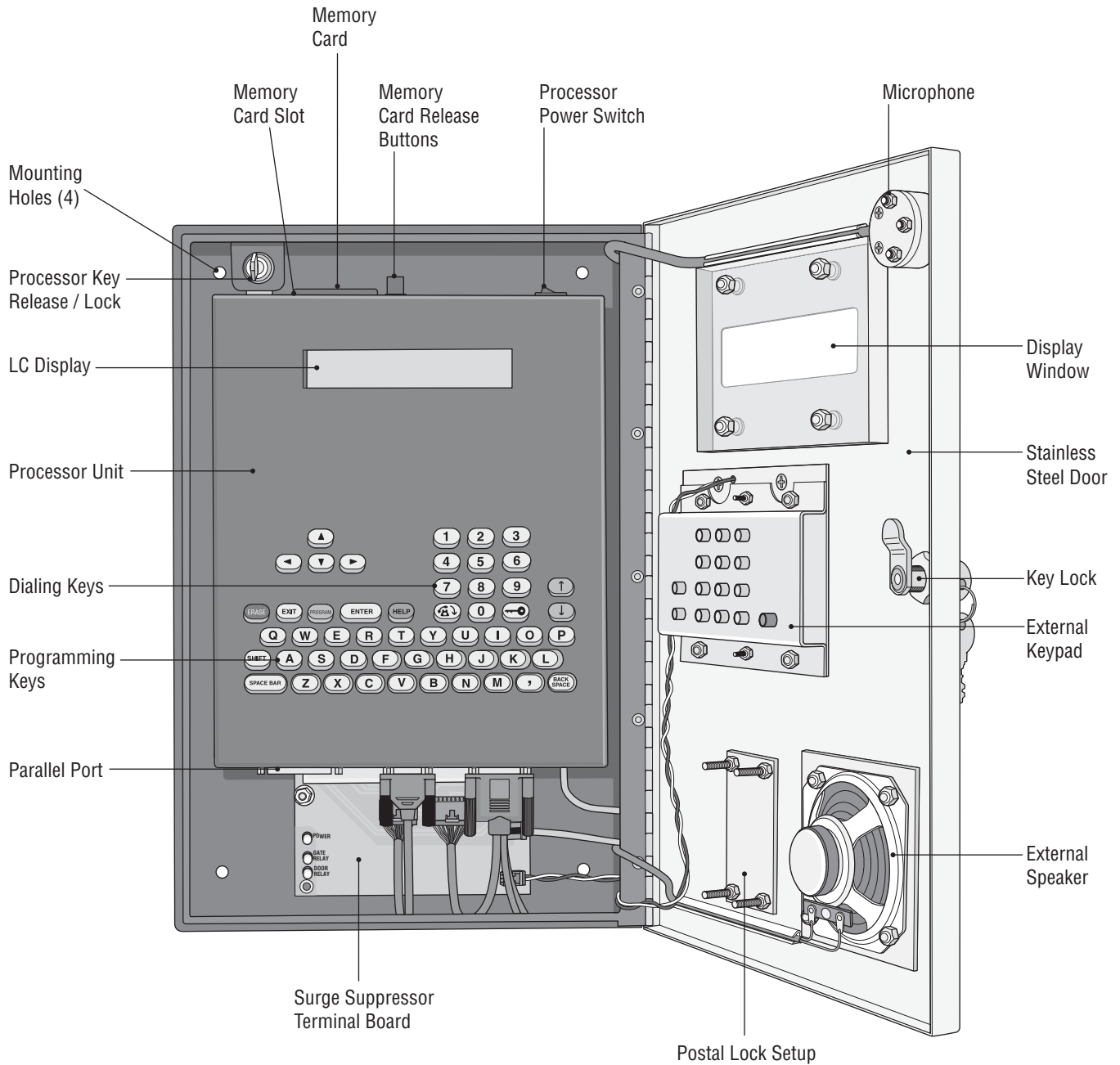

All components and specifications are subject to change without notice.

# LC ENTRY PHONE FEATURES (OUTSIDE)

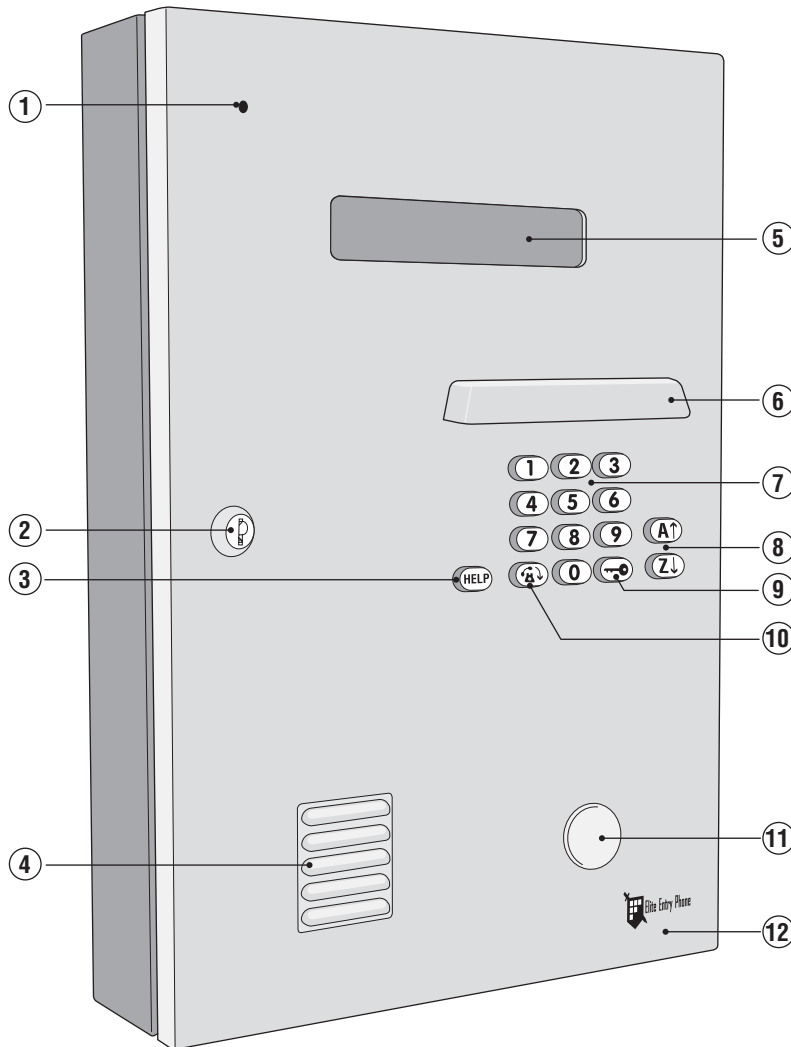

- ① **EXTERNAL MICROPHONE**
- ② **KEY LOCK** - Opens the Processor Containment Box to access the Processor.
- ③ **HELP KEY** - With digital voice messages to help guide the user.
- ④ **EXTERNAL SPEAKER**
- ⑤ **DISPLAY WINDOW** - Heavy-duty, 3/8" thick protective lens.
- ⑥ **DIALING KEYS LIGHT** - Lights up dialing keys for easy visibility.
- ⑦ **PHONE DIALING KEYS** - Used to dial residents / keycodes
- ⑧ **SCROLL KEYS** - Scrolls through names in alphabetical order on screen.
- ⑨ **UNLOCK KEY** - Residents and utility personnel use this key with their key code to open gate.
- ⑩ **HANG-UP KEY** - Pressed when user wants to hang up.
- ⑪ **ACCESS FOR POSTAL LOCK**
- ⑫ **16 GAUGE STAINLESS STEEL DOOR** - Heavy-duty and weather resistant.

All components and specifications are subject to change without notice.



# VF ENTRY PHONE FEATURES (INSIDE)

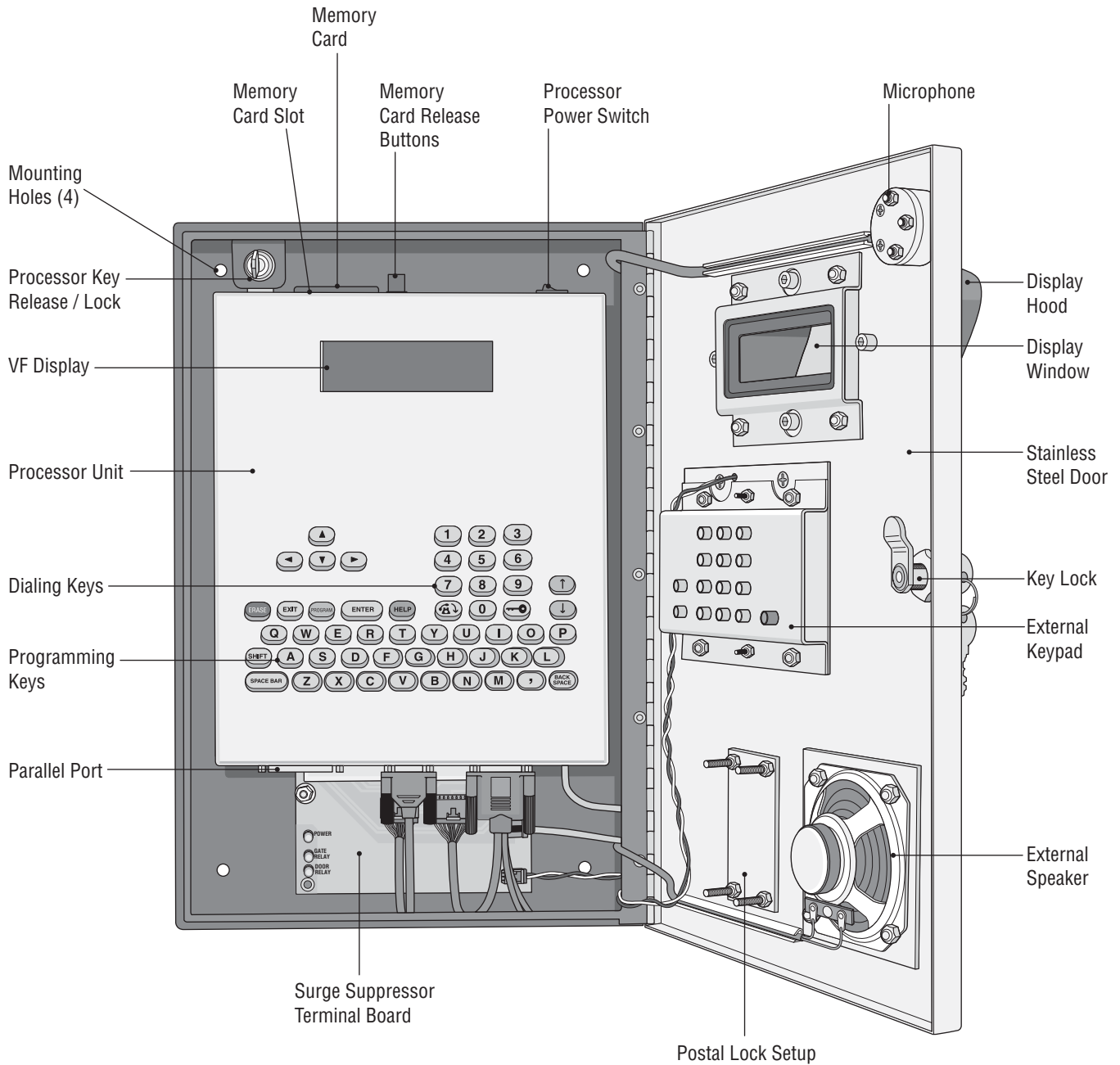

All components and specifications are subject to change without notice.



# VF ENTRY PHONE FEATURES (OUTSIDE)

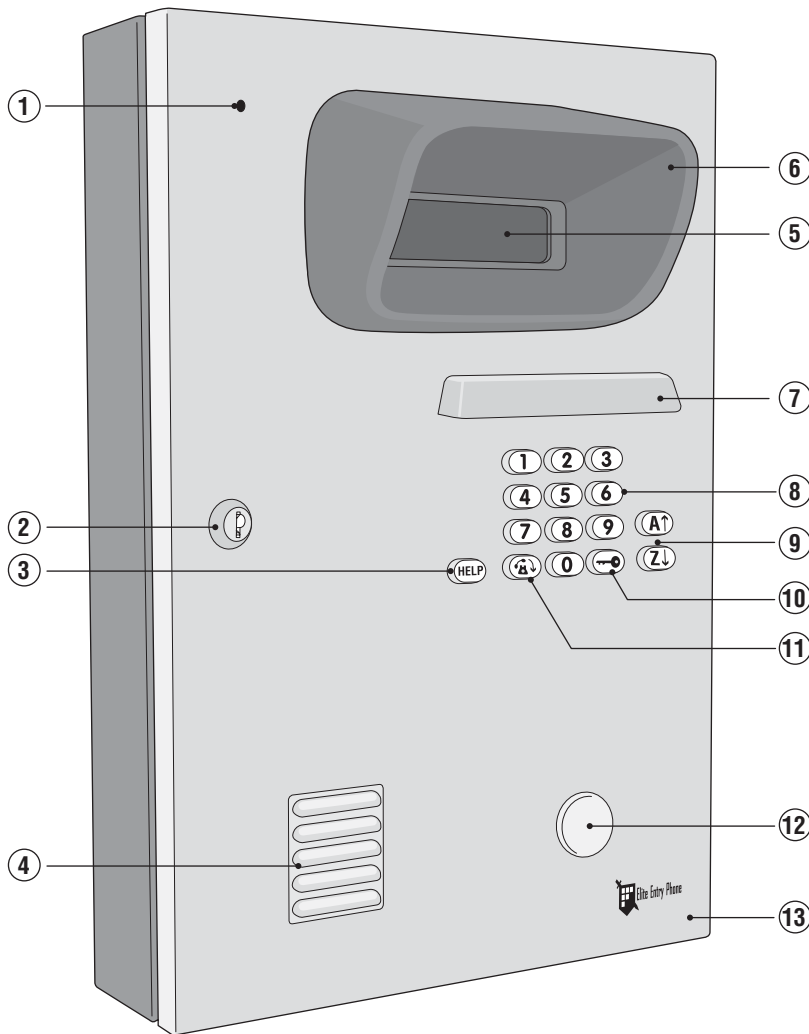

- ① **EXTERNAL MICROPHONE**
- ② **KEY LOCK** - Opens the Processor Containment Box to access the Processor.
- ③ **HELP KEY** - With digital voice messages to help guide the user.
- ④ **EXTERNAL SPEAKER**
- ⑤ **DISPLAY WINDOW** - Heavy-duty, 3/8" thick protective lens.
- ⑥ **DISPLAY HOOD** - Reduces reflections and direct sunlight.
- ⑦ **DIALING KEYS LIGHT** - Lights up dialing keys for easy visibility.
- ⑧ **PHONE DIALING KEYS** - Used to dial residents / keycodes
- ⑨ **SCROLL KEYS** - Scrolls through names in alphabetical order on screen.
- ⑩ **UNLOCK KEY** - Residents and utility personnel use this key with their key code to open gate.
- ⑪ **HANG-UP KEY** - Pressed when user wants to hang up.
- ⑫ **ACCESS FOR POSTAL LOCK**
- ⑬ **16 GAUGE STAINLESS STEEL DOOR** - Heavy-duty and weather resistant.

All components and specifications are subject to change without notice.

# ENTRY PHONE FEATURES (PROCESSOR)

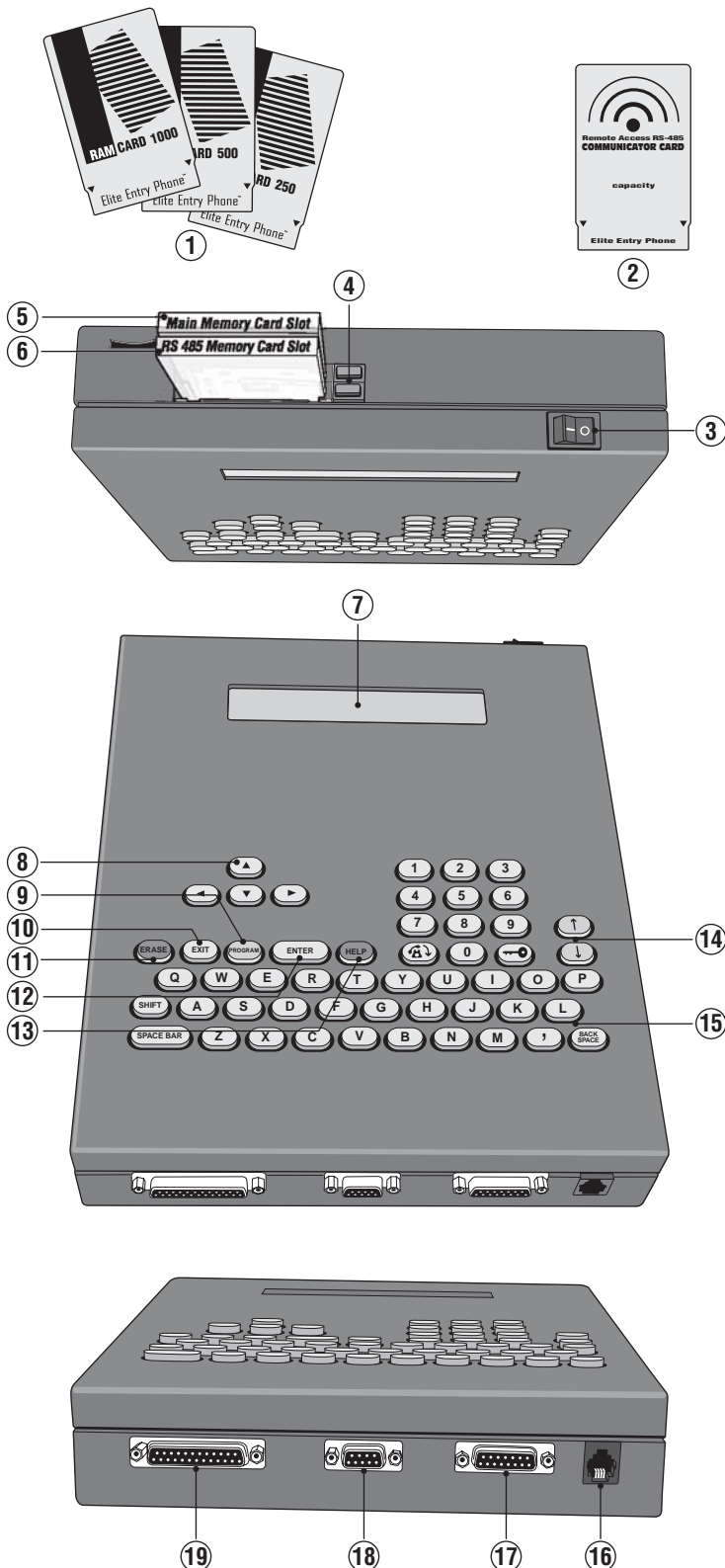

- ① **MEMORY CARD** - STORES ALL PROGRAMMED INFORMATION. (DIFFERENT MEMORY SIZES AVAILABLE)
- ② **COMMUNICATOR CARD** - CARD FOR RS-485 DEVICES.
- ③ **POWER ON/OFF SWITCH**
- ④ **CARD RELEASE BUTTONS** - EJECT CARDS WHEN PRESSED.
- ⑤ **MAIN MEMORY CARD SLOT** - HOLDS MAIN MEMORY CARD.
- ⑥ **RS 485 MEMORY CARD SLOT** - HOLDS RF COMMUNICATOR CARD OR BACKUP MEMORY.
- ⑦ **LCD TWO LINE, LARGE LIQUID CRYSTAL DISPLAY OR VF SUPER BRIGHT VACUUM FLUORESCENT DISPLAY SCREEN**- DISPLAYS INFORMATION AND INSTRUCTIONS, TWO LINES AT A TIME.
- ⑧ **DIRECTION KEYS** - MOVE CURSOR TO DESIRED POSITION WITHIN SCREENS.
- ⑨ **PROGRAM KEY** - SETS PROCESSOR TO THE PROGRAM MODE.
- ⑩ **EXIT KEY** - PRESS THIS KEY TO GO BACK TO THE PREVIOUS SCREEN / MENU.
- ⑪ **ERASE KEY** - ERASES INFORMATION SCREENS NO LONGER NEEDED.
- ⑫ **ENTER KEY** - REGISTERS INFORMATION INTO MEMORY AFTER IT IS TYPED.
- ⑬ **HELP KEY** - HELPS USER WHILE IN PROGRAMMING OR USER MODES.
- ⑭ **SCROLL KEYS** - SCROLLS THROUGH SCREENS / MENUS.
- ⑮ **KEYBOARD** - WORKS LIKE STANDARD KEYBOARD TO TYPE IN INFORMATION AND NAMES.
- ⑯ **PHONE JACK (RJ11)** - CONNECTS TO SURGE SUPPRESSOR TERMINAL BOARD.
- ⑰ **INPUT/OUTPUT CONNECTOR** - CONNECTS TO SURGE SUPPRESSOR TERMINAL BOARD.
- ⑱ **COMMUNICATION PORT** - CONNECTS TO SURGE SUPPRESSOR TERMINAL BOARD.
- ⑲ **PARALLEL PORT** - USED FOR THE ICON26 ONLY.

All components and specifications are subject to change without notice.

# LC MOUNTING INSTALLATION

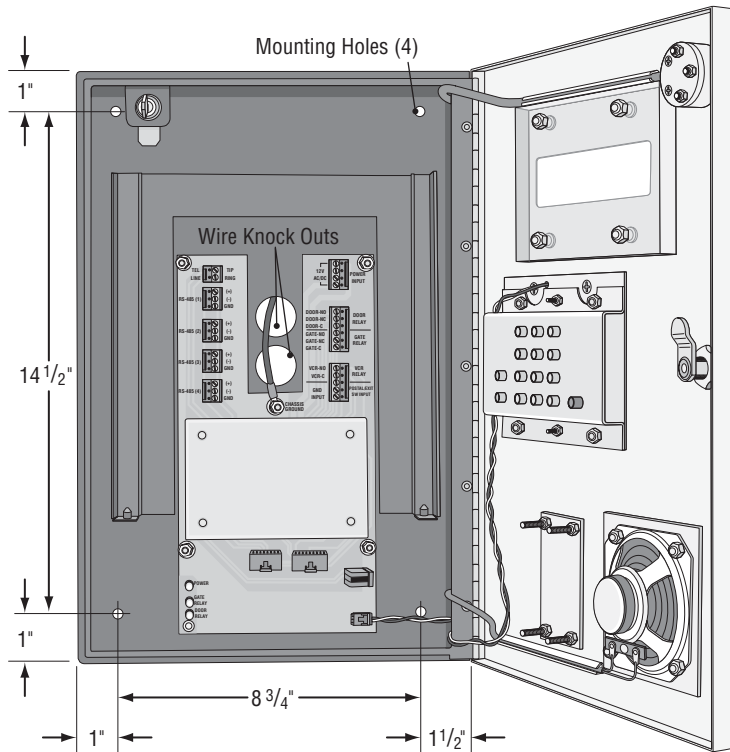

## Installation on Wall

Remove the Processor Unit from the Processor Containment Box and bolt the Processor Containment Box to the recess in the wall using the four mounting holes. Feed the power and phone lines through the knockout in the back of the box to make all wire connections.

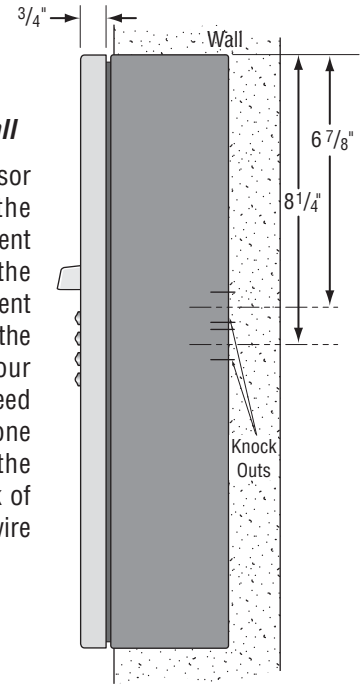

Front View

Side View

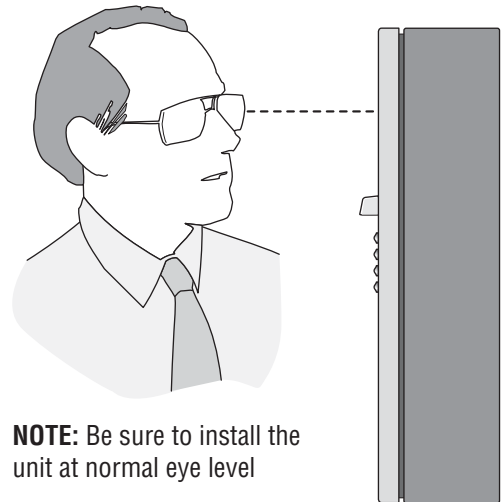
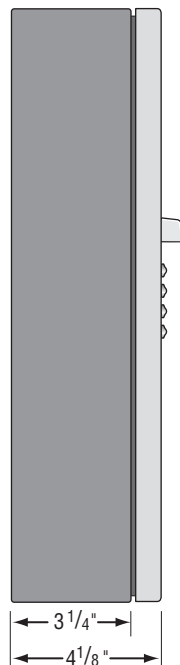
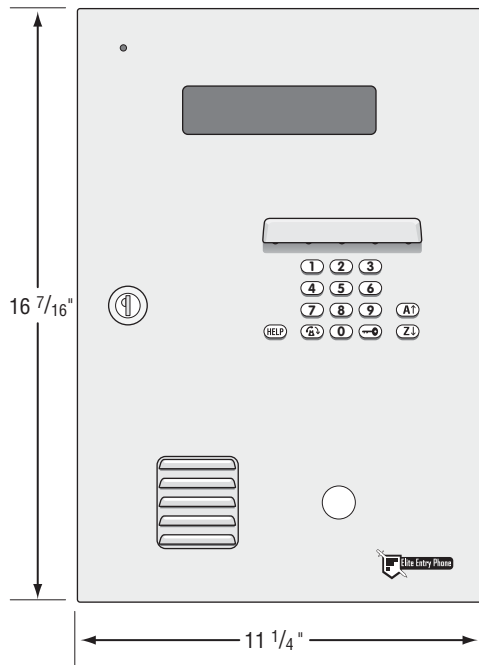

**NOTE:** Be sure to install the unit at normal eye level



Be sure to read and follow all Elite instructions before installing and operating any Elite products. Elite Entry Phone is not responsible for improper installations or failure to comply with local building codes.

All components and specifications are subject to change without notice.

# VF MOUNTING INSTALLATION

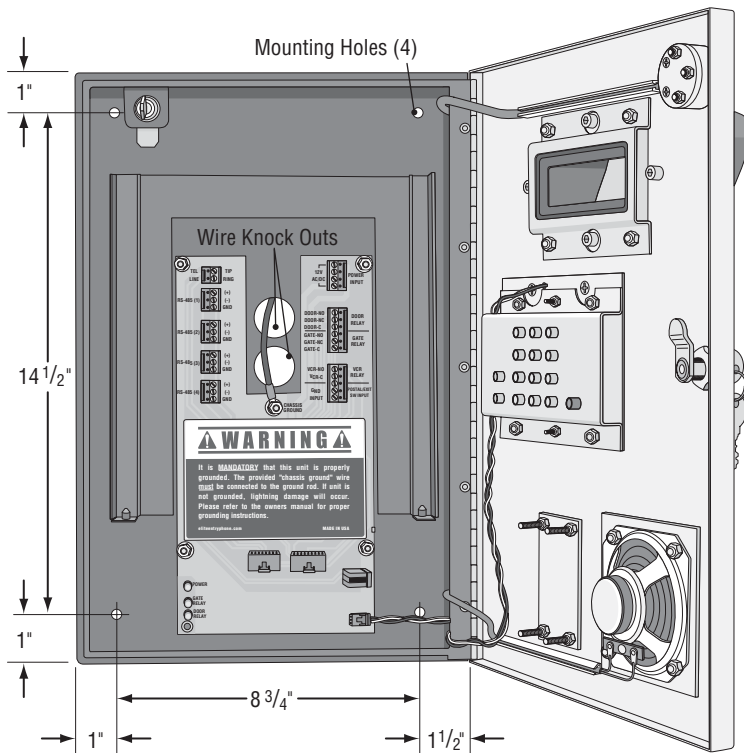

## Installation on Wall

Remove the Processor Unit from the Processor Containment Box and bolt the Processor Containment Box to the recess in the wall using the four mounting holes. Feed the power and phone lines through the knockout in the back of the box to make all wire connections.

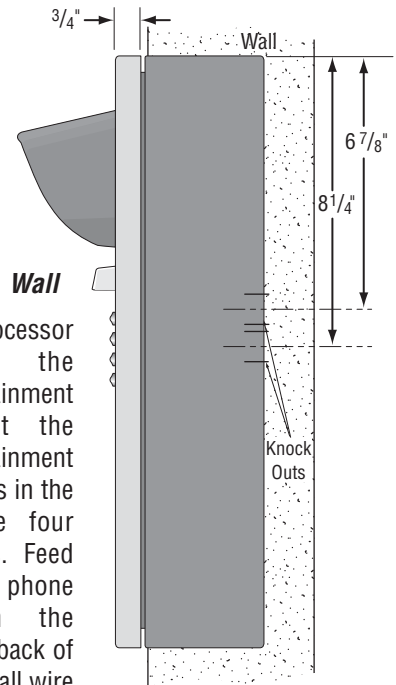

Front View

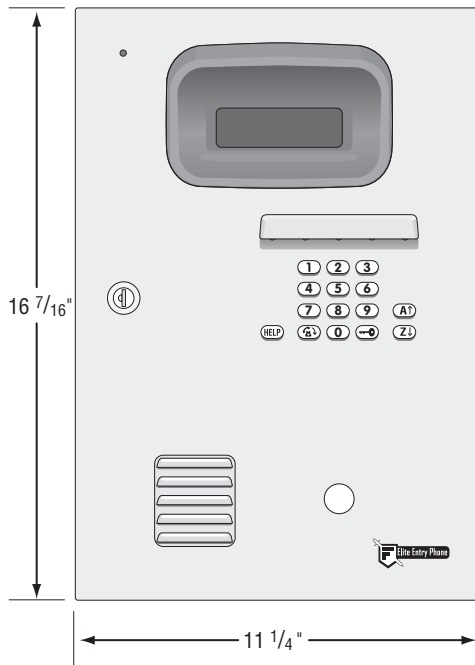

Side View

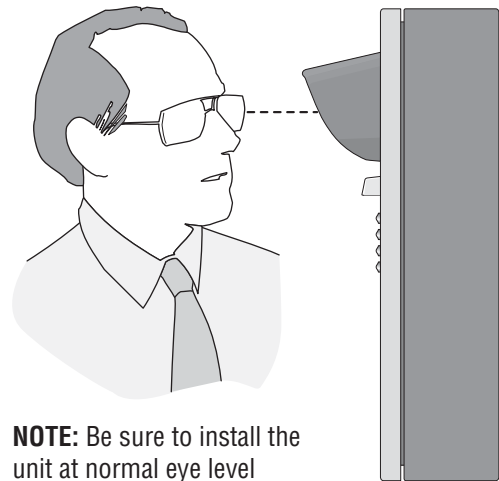
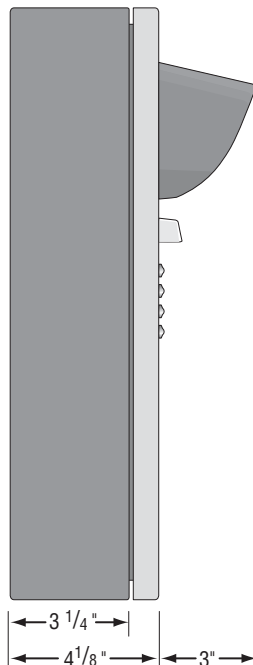

Be sure to read and follow all Elite instructions before installing and operating any Elite products. Elite Entry Phone is not responsible for improper installations or failure to comply with local building codes.

All components and specifications are subject to change without notice.

# DESCRIPTION OF SURGE SUPPRESSION TERMINAL BOARD

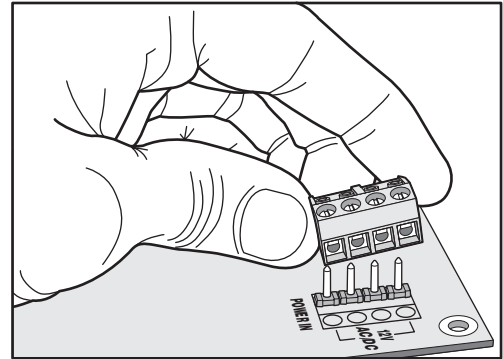
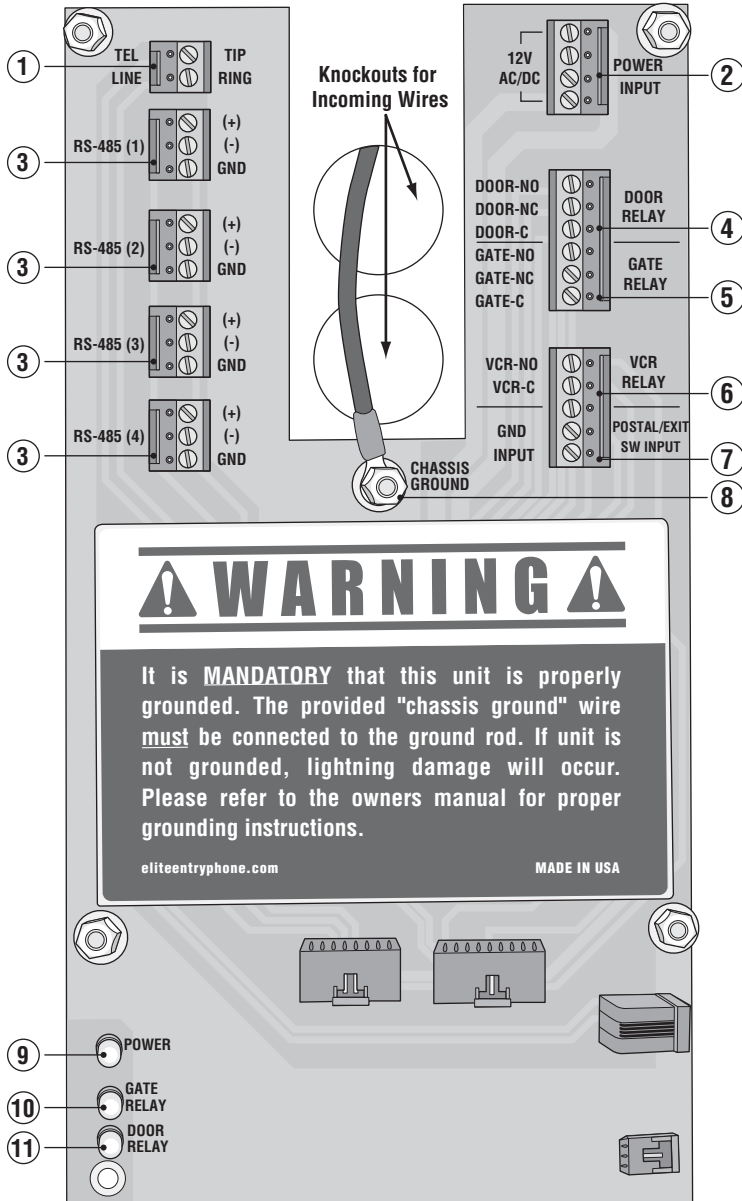

Removable Screw Terminal Connectors for Easy Wiring.

- 1 TELEPHONE LINE: Tip and Ring Connection.
- 2 POWER IN: 12 VAC transformer input.
- 3 RS 485: Connect to corresponding RS485 terminals (-, +, GND) of remote security devices.
- 4 DOOR RELAY: For allowing access through pedestrian gate or door.
- 5 GATE RELAY: For use with gate operator to control access through main vehicular gate.
- 6 VCR RELAY: For use with Time Lapse VCR. Each time access is granted, the VCR Relay is activated for 5 seconds, allowing recording of all access to facility.
- 7 POSTAL/EXIT SW INPUT: For allowing postal lock access to pedestrian gate or door. Activates gate relay using gate strike time.
- 8 CHASSIS GROUND: Entry Phone **MUST** be properly grounded. Refer to "Grounding the Unit" and "Earth Ground Rod Installation" sections.
- 9 POWER LED: Indicates Entry Phone has 12 VAC power.
- 10 GATE RELAY LED: Indicates gate relay is activated.
- 11 DOOR RELAY LED: Indicates door relay is activated.

**NOTE:** Telephone line used for Entry Phone system must be a dedicated line.

# GROUNDING THE UNIT

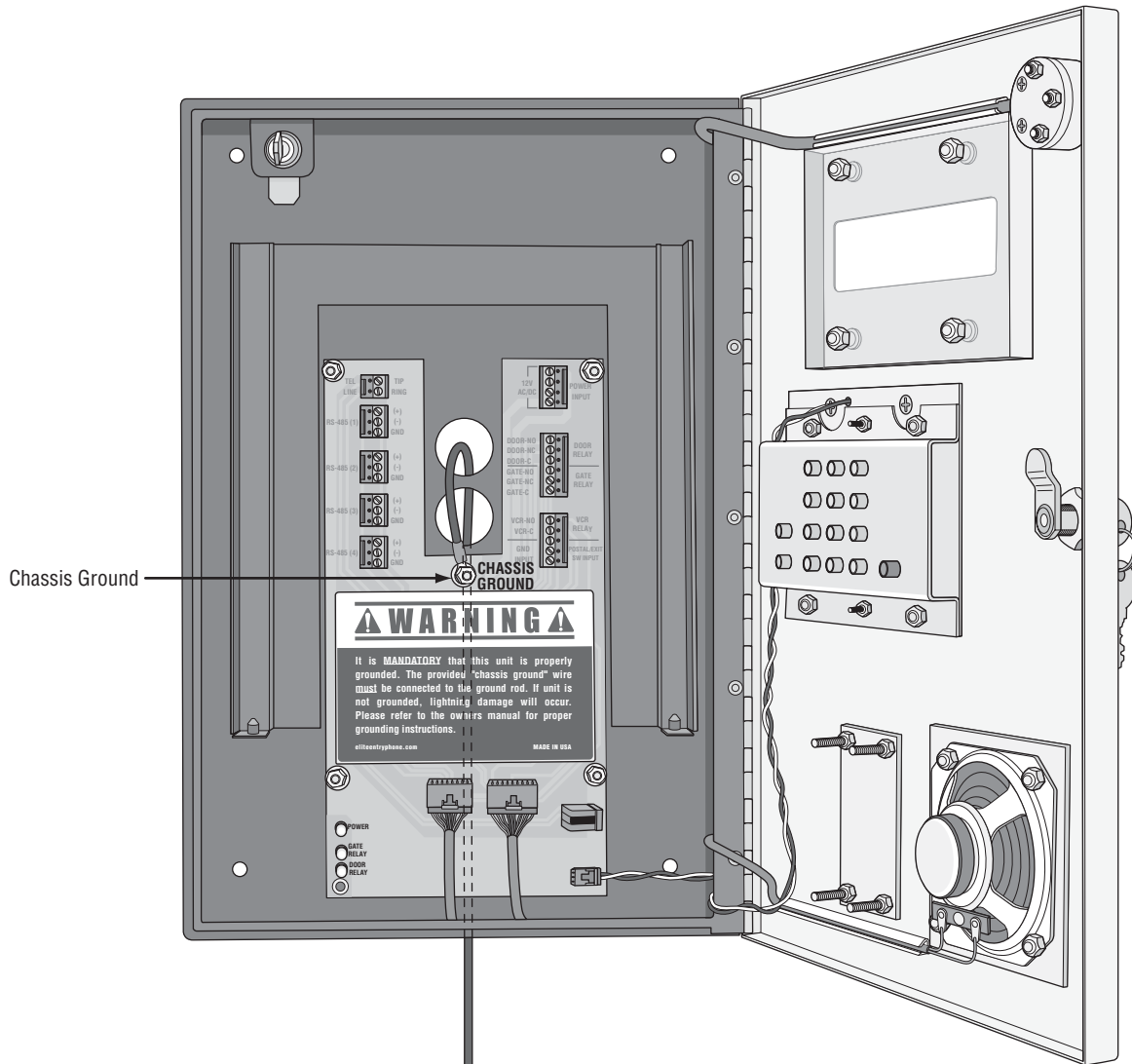

Ground Rod



Refer to the next page for ground rod installation.

## **⚠ WARNING ⚠**

It is **MANDATORY** that this unit is properly grounded. The provided "chassis ground" wire **must** be connected to the ground rod. If unit is not grounded, lightning damage will occur.

# EARTH GROUND ROD INSTALLATION

Proper grounding gives an electrical charge, such as from an electrical static discharge or a near lightning strike, a path from which to dissipate its energy safely into the earth.

Without this path, the intense energy generated by lightning could be directed towards the Elite Entry Phone System. Although nothing can absorb the tremendous power of a direct lightning strike, proper grounding can protect the Entry Phone System in most cases.

The type and length of earth ground rods vary by region. Contact the building inspector's office in the municipality where you plan to install the unit for correct grounding materials and installation procedures.

***Before digging, contact local underground utility locating companies.  
Avoid damaging gas, power, or other underground utility lines.***

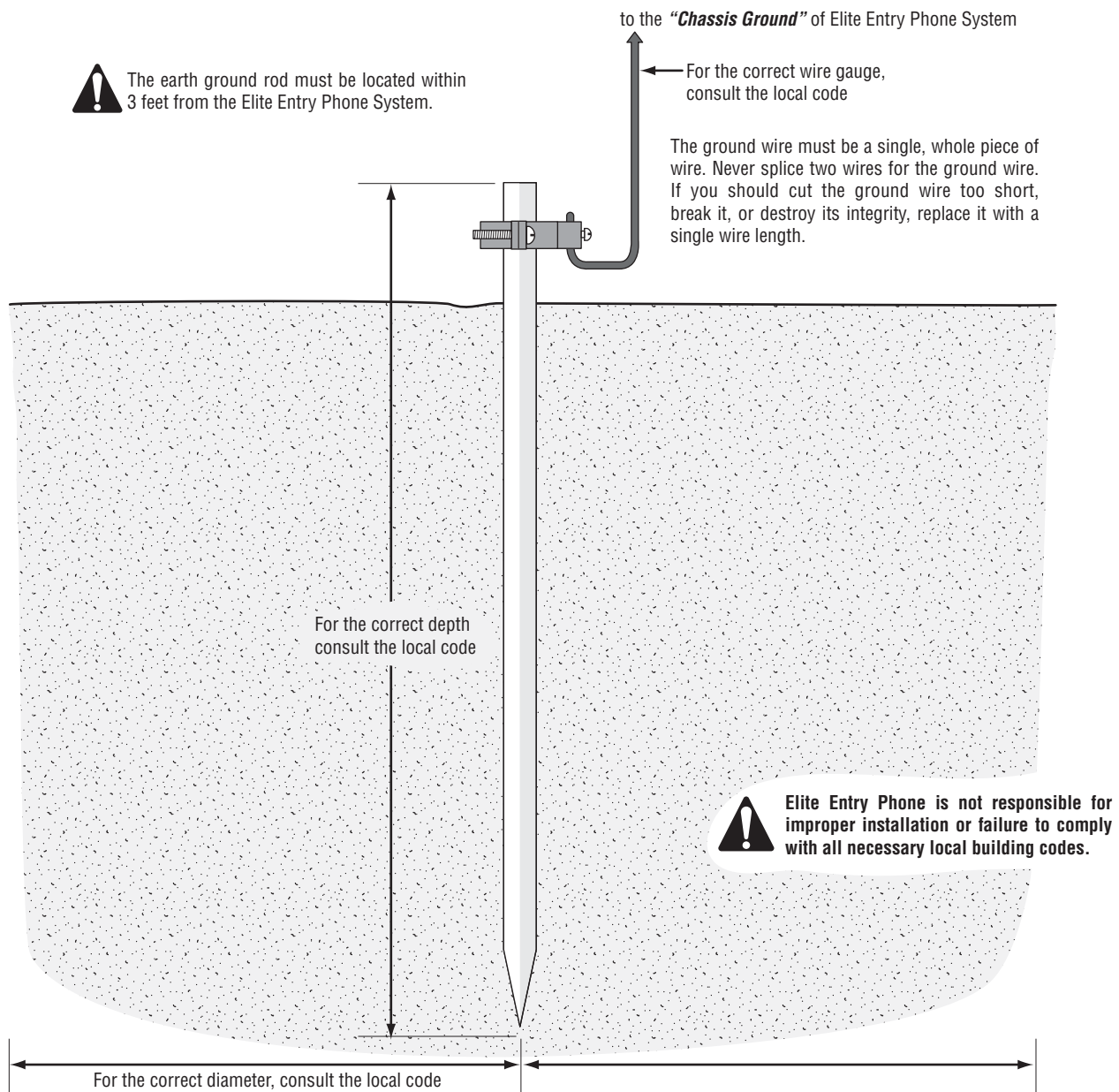



# BASIC WIRING DIAGRAM

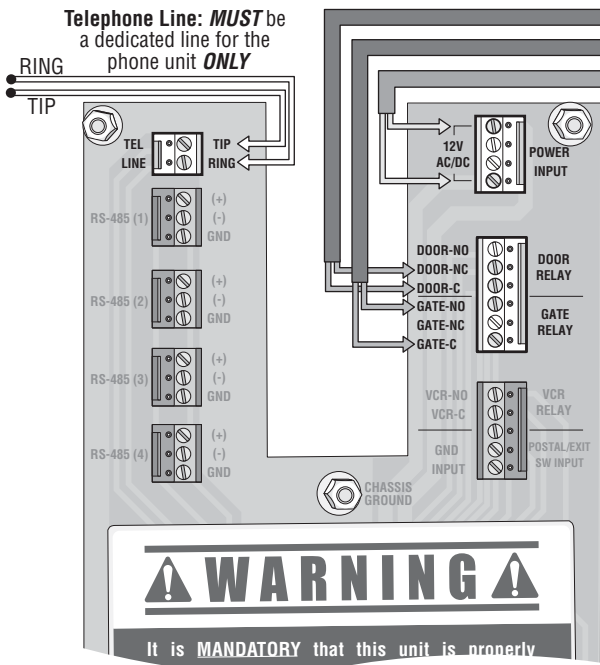

Use 18 AWG wire where possible

Polarity does not matter

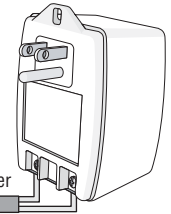

**Processor Transformer**  
12 VAC (50VA) Provided

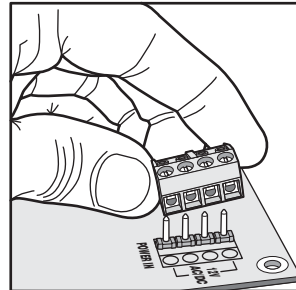

Removable Screw Terminal Connectors for Easy Wiring.

Wire Gauge	12 VAC (50 VA) Maximum Distance
24 AWG	85 Ft
22 AWG	140 Ft
20 AWG	225 Ft
18 AWG	350 Ft
16 AWG	560 Ft

**Entry 1** Gate Relay Terminal Connection

**Vehicular Gate**

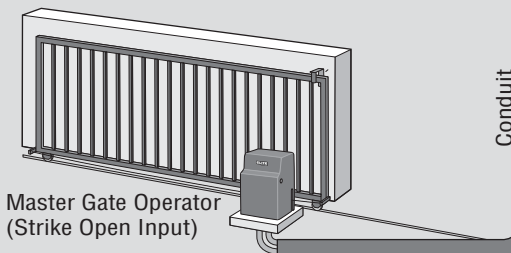

**Entry 2** Door Relay Terminal Connection

**Pedestrian Gate**

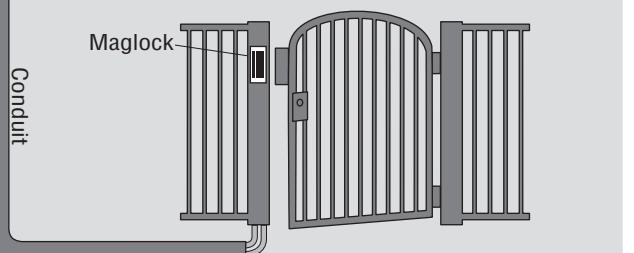

OR

**Access Door**

Solenoid

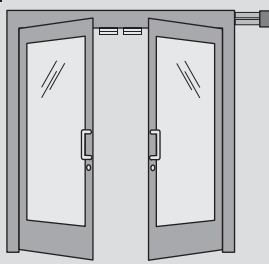

Dial **9**



OR

**Entry Door**

Maglock

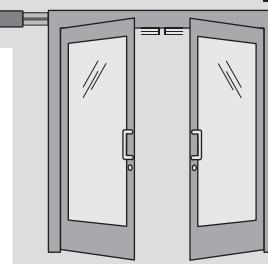

Dial **5**

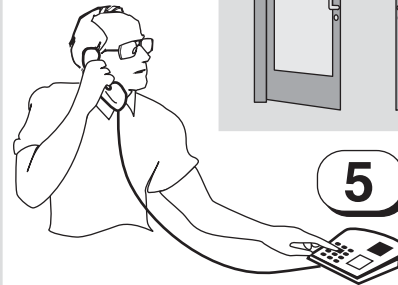

Connect two wires to the *main* vehicular gate operator or door. The gate relay will be activated by either pressing 9 on the resident's phone, entering a utility or resident keycode, *Gate 7-day timer* or *ElitePro remote programming software*.

Connect two wires to the *secondary* gate or door. The door relay will be activated by either pressing 5 on the resident's phone, *Door 7-day timer* or *ElitePro remote programming software*.

# POSTAL LOCK INSTALLATION

These parts are used only when postal access to your facility is required. The postal lock mechanism must be obtained by application to your local post office.

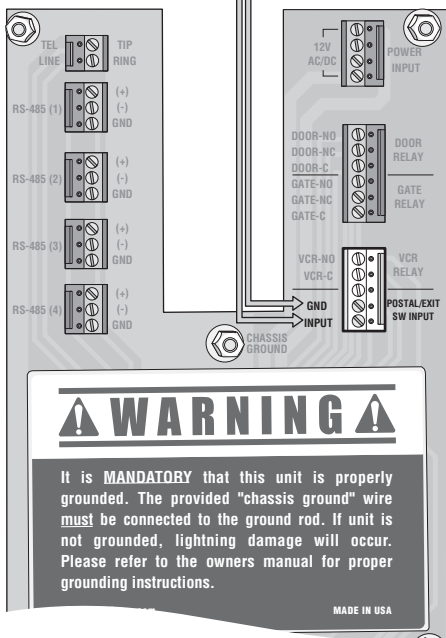
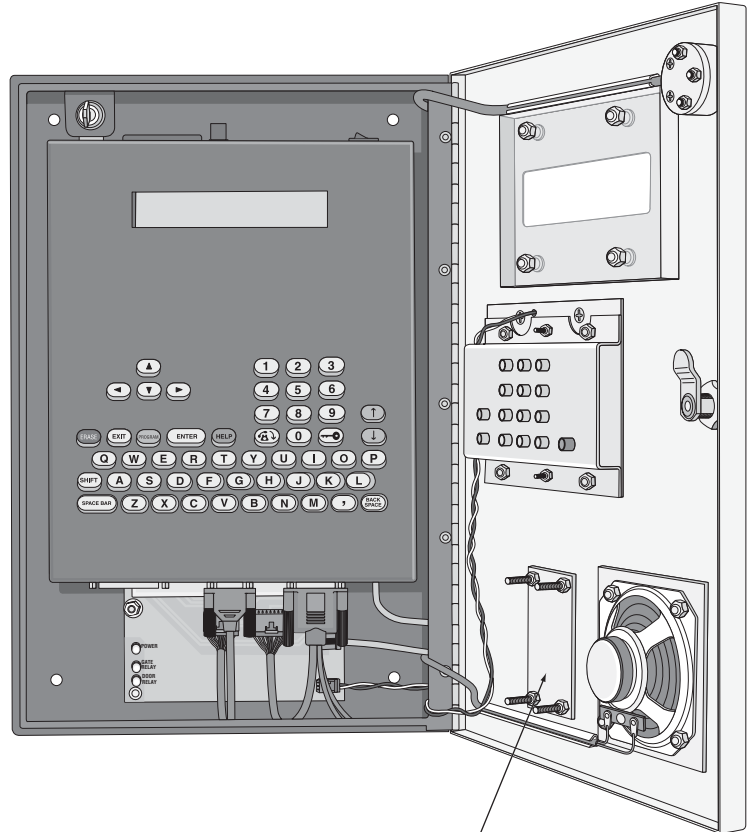
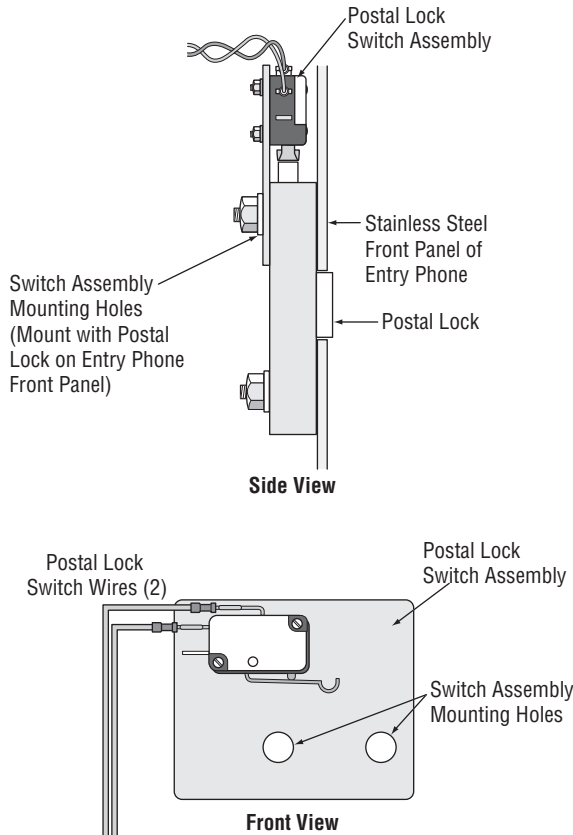

## Installation:

- 1 Open the front panel of the Entry Phone and remove the hole plug.
- 2 (Retain nuts and washers) Install the postal lock with the sliding bolt oriented away from the speaker.
- 3 Install the enclosed plate end switch assembly over the sliding bolt so that when the bolt is extended it will activate the switch as shown in the diagram.
- 4 Fasten by using the enclosed flat washer, lock washer, and nut on each of the four studs. Adjust the plate and switch location as the nuts are tightened to ensure switch activation when the bolt is extended.
- 5 Connect the two wires from the postal lock switch to the postal/exit connector on the surge suppressor terminal board. Note that polarity or color coding is not required. When the postal lock is engaged, the system's gate relay is activated for a duration according to the programmed "Gate Strike Time".
- 6 Test operation by activating the lock. Ensure that full extension of the sliding bolt will not bend or break the switch.

# RS-485 CONNECTION CONFIGURATIONS

## Configuration #1 "Daisy Chain" wiring configuration

(Recommended method for superior data transmission)

- Up to **31** RS-485 devices supported
- Maximum distance from the last RS-485 device to the Entry Phone is 4000 Ft.
- Turn "ON" the terminator switch *ONLY* for the last device installed in the RS-485 line.
- Use 22 AWG twisted pair shielded wire

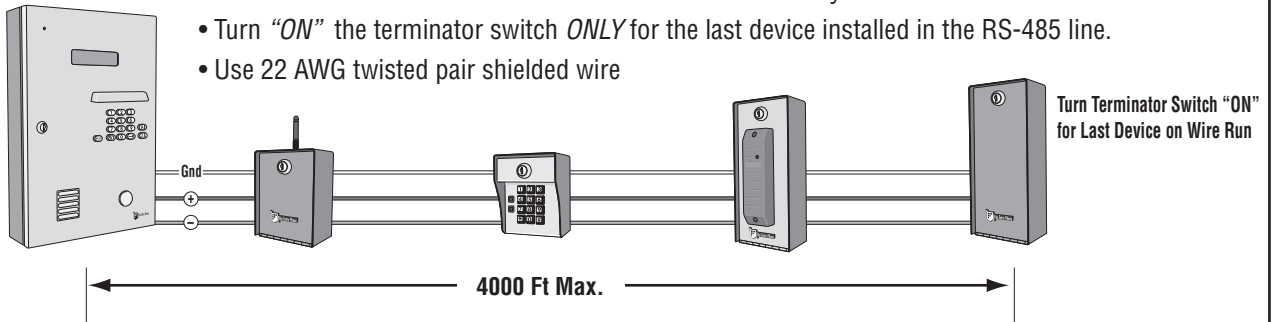

Each RS-485 device must have a unique "Device ID Number" set by using the rotary switches on the device. (Refer to specific RS-485 Instruction sheets).

## Configuration #2 "Star" wiring configuration

- Maximum number of wire runs allowed is **7**
- Maximum distance from the last RS-485 device (per wire run) to the Entry Phone is 4000 Ft.

- Maximum number of RS-485 devices present on *ALL* wire runs is **31**.
- Use 22 AWG twisted pair shielded wire

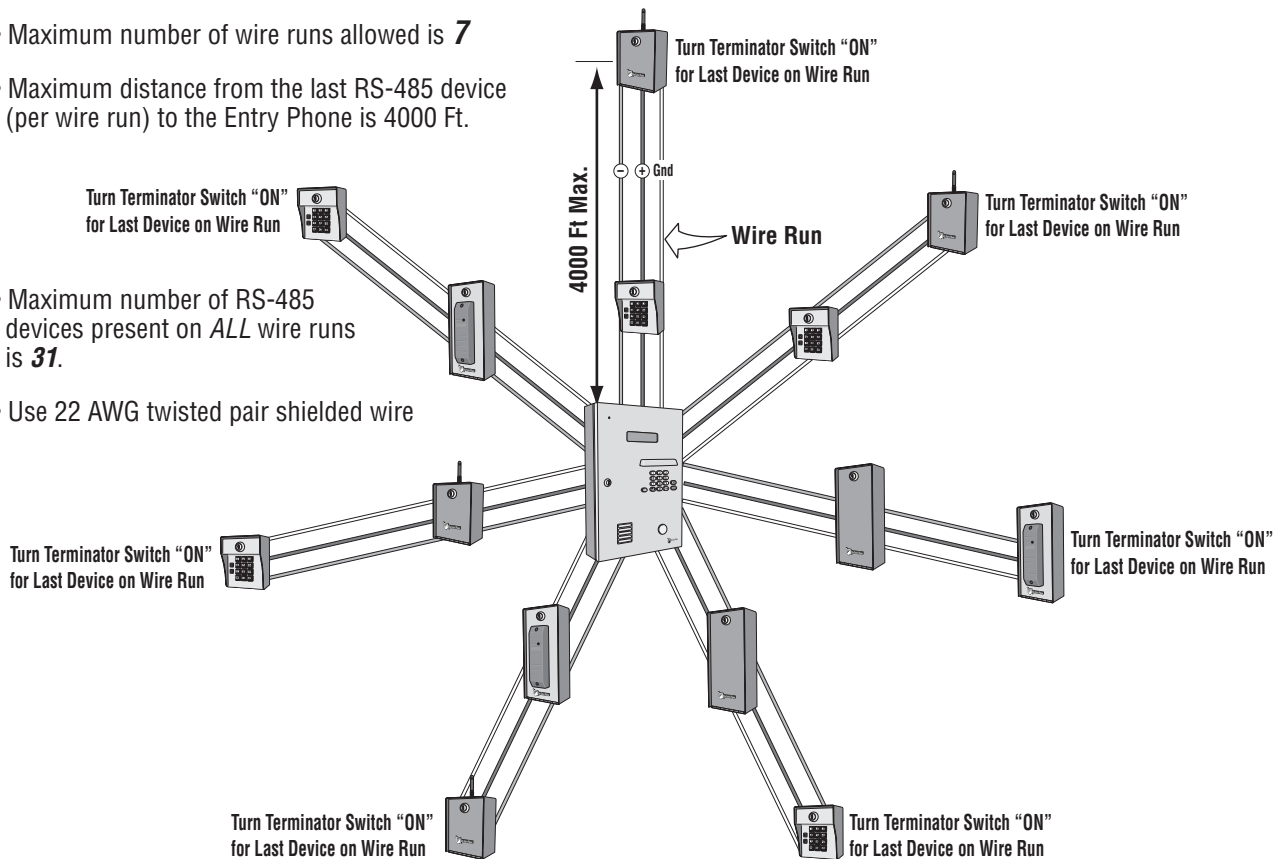

Each RS-485 device must have a unique "Device ID Number" set by using the rotary switches on the device. (Refer to specific RS-485 Instruction sheets).

# RS-485 DAISY CHAIN CONNECTION EXAMPLE

## “Preferred Method”

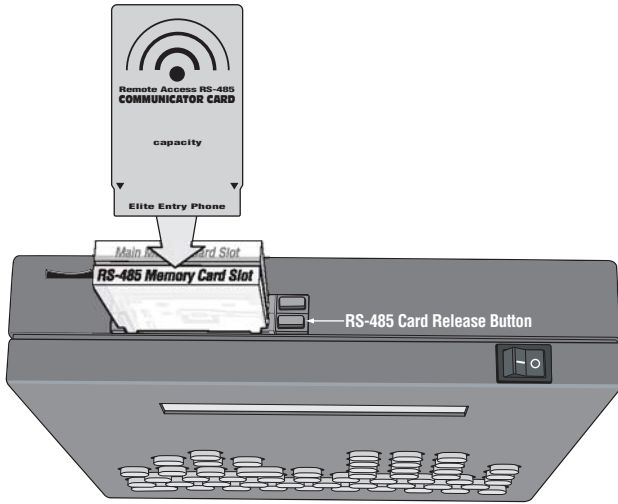

**NOTE:** To support RS-485 devices you must insert the RF communicator card in the RS-485 memory card slot **BEFORE** turning on the processor.

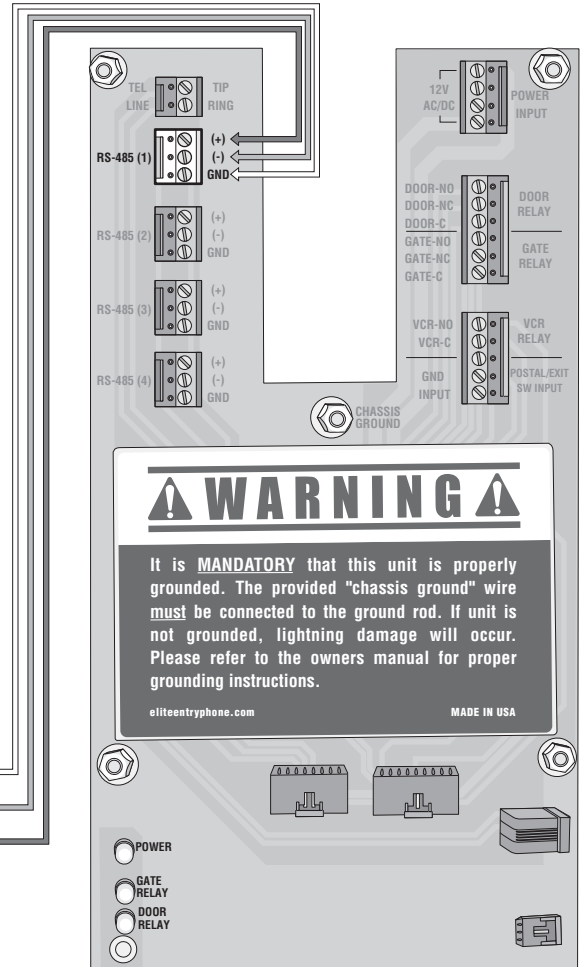

Ground

(-)

(+)

**! Use 22 AWG Twisted Pair Shielded Wire**



**Keypad  
RS-485 Remote  
Device 1**

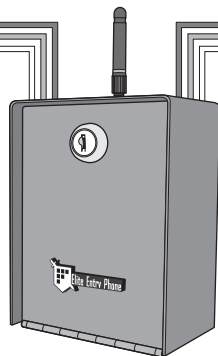

**Stand-Alone Receiver  
RS-485 Remote  
Device 2**

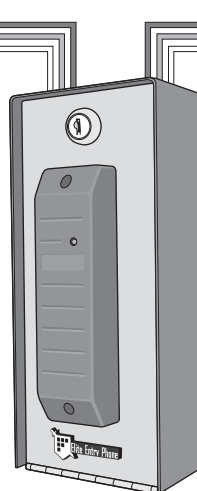

**Card Reader  
RS-485 Remote  
Device 3**

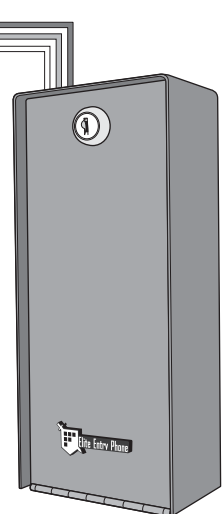

**Universal Interface Board  
RS-485 Remote  
Last Device**

# RS-485 STAR CONNECTION EXAMPLE

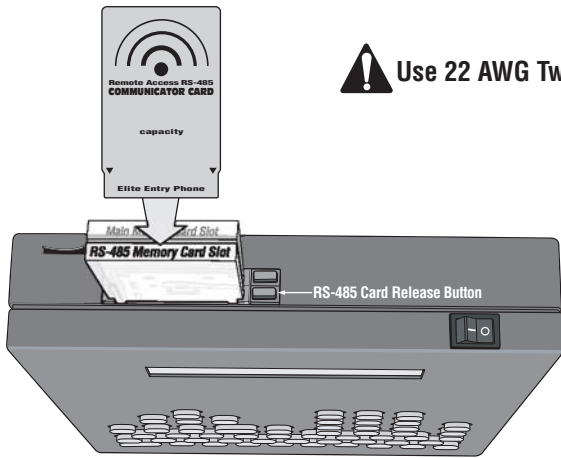

**!** Use 22 AWG Twisted Pair Shielded Wire

**NOTE:** To support RS-485 devices you must insert the RF communicator card in the RS-485 memory card slot **BEFORE** turning on the processor.

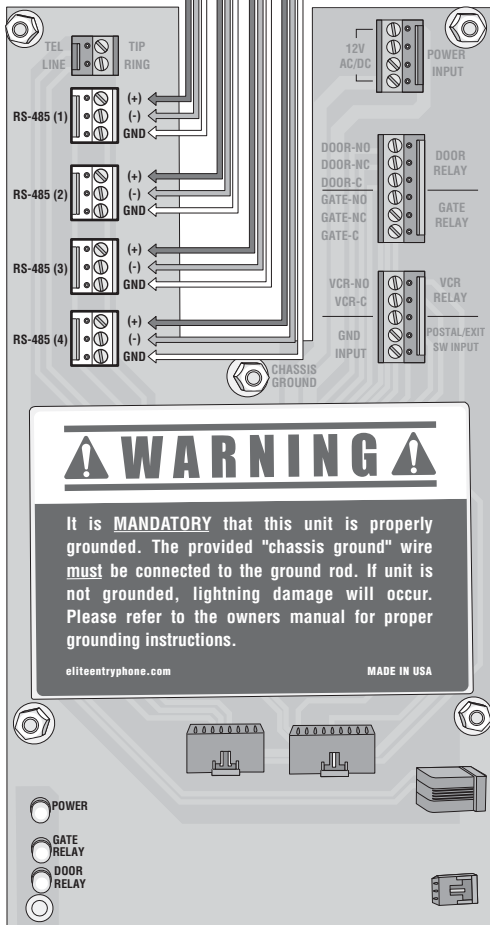

## ! WARNING !

It is **MANDATORY** that this unit is properly grounded. The provided "chassis ground" wire **must** be connected to the ground rod. If unit is not grounded, lightning damage will occur. Please refer to the owners manual for proper grounding instructions.

eliteentryphone.com

MADE IN USA

- POWER
- GATE RELAY
- DOOR RELAY

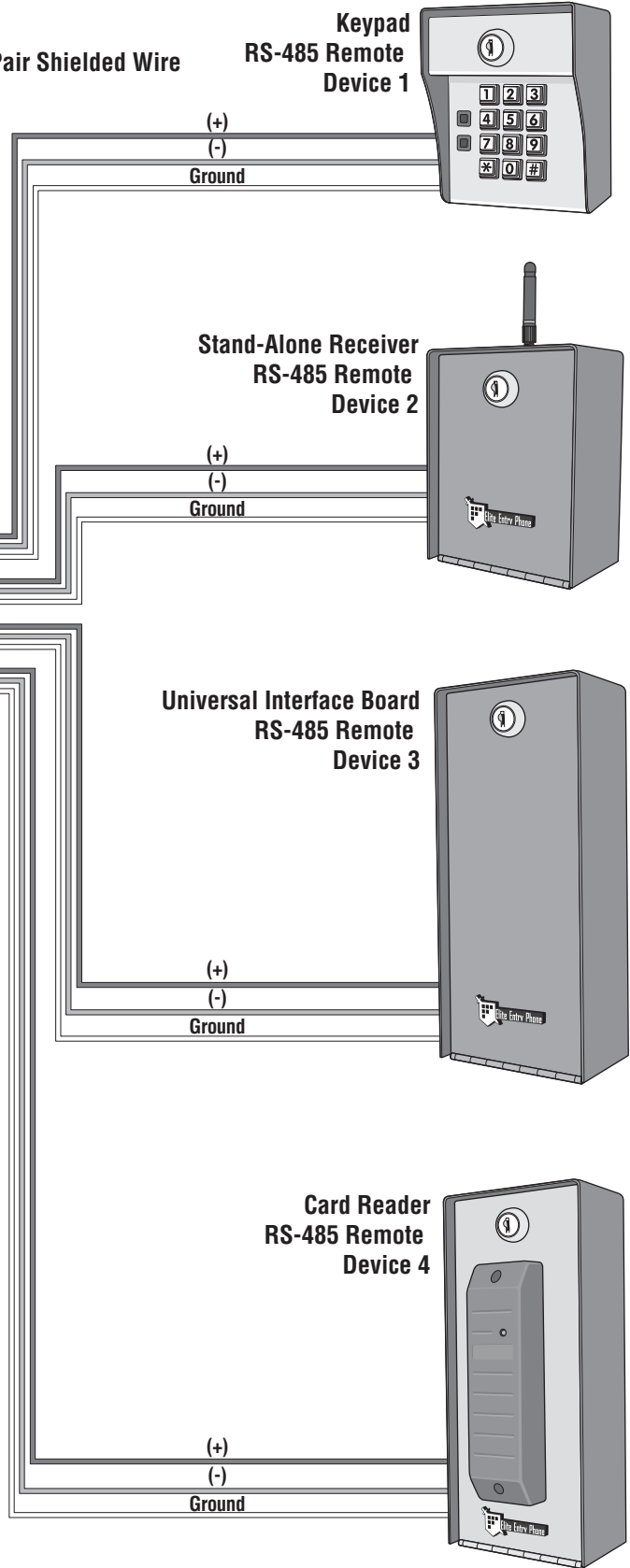

# MEMORY CARD INSTALLATION

Turn power on and insert Memory Card into Main Memory Card Slot (Main Memory Card in back slot, Backup Memory Card in front slot.) (*fig a.*) Push it all the way in until card “snaps” into place and the release button pops up. The screen should display the “*Welcome Screen*” (*fig b.*)

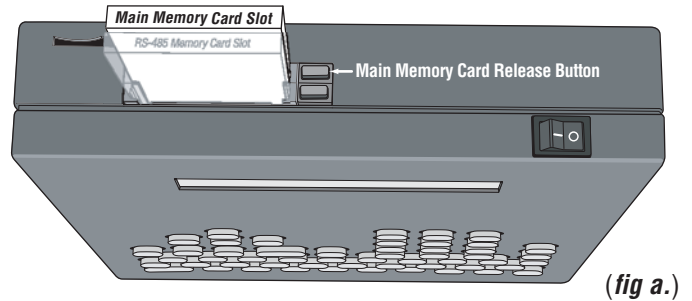

(*fig a.*)



(*fig b.*)

If the screen continues to display the “*Insert Memory Card*” screen (*fig c.*) then eject memory card by pressing the corresponding release button down and reinsert Memory Card into main slot (*fig d.*). Otherwise continue with programming.



(*fig c.*)

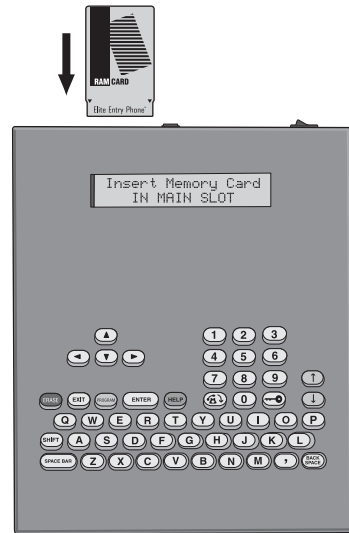
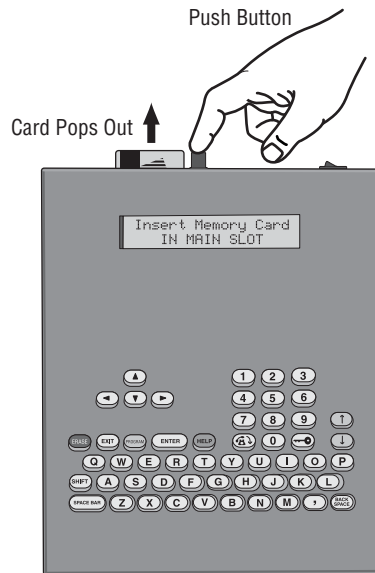

(*fig d.*)

# VIEWING THE SOFTWARE VERSION

To view the memory capacity of the system or to view the software version currently running on the system in operation an information screen is accessible on all Dial Code systems for easy reference. Turn power off and insert Memory Card in Main Memory Slot. Turn power on and the information screen should display as seen in (*fig e.*)

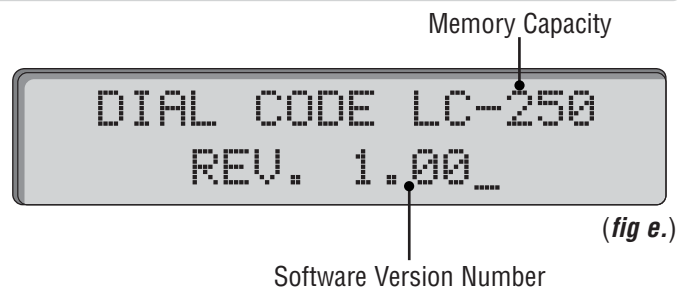

(*fig e.*)

# WARNINGS AND PRECAUTIONS

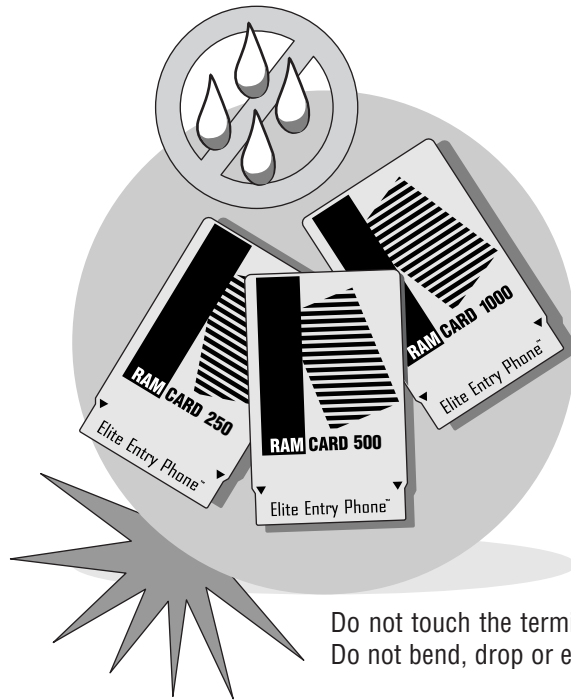

Do not touch the terminals on the RAM Cards.  
Do not bend, drop or expose to impact.



The Entry Phone is only water resistant when the Stainless Steel Door is closed and locked. Do not expose the Processor Unit or the open Processor Containment Box to rain, snow, or harsh weather conditions. Do not drop the Processor or expose it to impact.



# PROGRAMMING THE PROCESSOR

## ENTERING THE PROGRAM MODE

When the Processor unit is turned on and the **PROGRAM** button is pressed, the screen will display:

```
TO ENTER PROG MODE,  
Type Password >_____
```

Type in the factory present password (7777). Press **ENTER**. The Program Selection Screen will display:

```
SELECT PROG MODE: ↓  
(N)Names (U)Utility
```

If you enter the wrong password, the screen will prompt you to try again:

```
INVALID PASSWORD  
(R)Retry (EXIT)Quit
```

Press **R** to retry entering your password. Press **EXIT** to quit the programming menu.

Pressing the **HELP** button will provide users with a help message.

**IMPORTANT NOTE:** While in the help screens, programming will be disabled.



To continue programming, press the **EXIT** button to exit the help screens first.

# SELECTING PROGRAM MODE

## LIST OF PROGRAM MODES:

1	Names	N	Program or edit Resident Names	page 24-26
2	Utility	U	Program or edit Utility Codes	page 27
3	Password*	P	Program New Password ( recommended )	page 28
4	Clock/Timer	C	Program System Clock and Seven Day Timers	pages 29-31
5	Strike Time	S	Program relay output time ( for 2 relays )	page 32
6	Talk Time	T	Program length of Talk Time	page 32
7	Greeting	G	Program custom Welcome Screen Message	page 33
8	Volume	V	Program Volume level	page 33
9	Backup	B	Backup of memory card	page 34

\*We recommend you customize your password to avoid unauthorized programming (see “Password” section)  
To select a Program Mode, press the corresponding letter from one of the nine options.

Use the   keys to scroll through the nine different Program Modes.

```
SELECT PROG MODE: ↓
(N)Names (U)Utility
```

```
SELECT PROG MODE: ↓↑
(S)Strike Time
```

```
SELECT PROG MODE: ↓↑
(P>Password
```

```
SELECT PROG MODE: ↓↑
(T)Talk Time
```

```
SELECT PROG MODE: ↓↑
(C)Clock/Timer
```

```
SELECT PROG MODE: ↓↑
(G)Greeting
```

```
SELECT PROG MODE: ↑
(U)Volume (B)Backup
```

Pressing the  button will provide users with a help message.

**IMPORTANT NOTE:** While in the help screens, programming will be disabled.  
To continue programming, press the  button to exit the help screens first.

# RESIDENT INFORMATION

**STEP 1** In the Program Selection Screen (*fig a.*), Press the **(N)** key. The screen will display (*fig b.*):



**STEP 2** You now have three options:

To program by name, press the **(N)** key and the first empty code will display.

**OR**

To program by code, enter a three digit code\* and press the **(ENTER)** key.

**OR**

To view or edit an existing name or code, use the **(↑)** **(↓)** keys to scroll through Directory.

\* The unit will only accept codes within it's range - depending on memory capacity.

**STEP 3** Type in the desired Resident name, LAST name first, followed by the first name (*fig c.*). If the code you have selected is already used, there will be a name already. You can edit the name by simply typing over it. Press the **(ENTER)** key to complete the entry. You may also use the **(←)** **(↑)** **(↓)** **(→)** keys to move the cursor within a code.

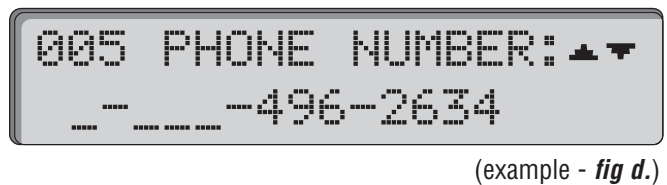
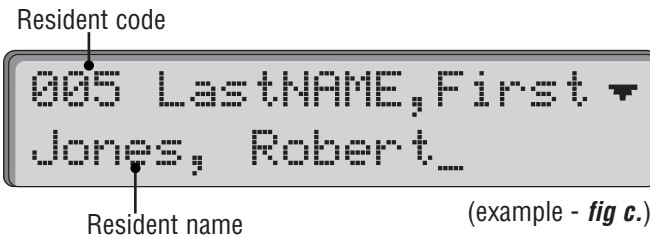

**STEP 4** Type in the desired Resident phone number (*fig d.*). If you need to enter an area code refer to the area code page. Press the **(ENTER)** key to complete the entry. The **"KEY CODE"** screen will be displayed. (*fig e.*)

**STEP 5** An individual six digit Resident Key code may be assigned to each resident . Residents can use their Key Code to access the premises.



Assignment of Resident Key Codes is optional. The first three digits of the Key Code is the assigned Directory Code. Assign the last three digits (numeric characters only) to create an individual Key Code. If using the RF Card, proceed to Step 6 (*fig e.*). Press the **(ENTER)** key.

# TRANSMITTER/CARD PROGRAMMING

**STEP 6** To complete entry, press the **EXIT** key to return to the program selection screen.  
To program RF devices ( i.e. transmitters/cards etc.) continue on to Step 7.

**NOTE:** To enable the transmitter/card programming feature, you must insert the communicator card in the “backup” slot **before** you turn on unit. (refer to “Memory Card Installation” section)

**STEP 7** Use **▼** **▲** keys to view and program up to 10 transmitter or card codes associated to the directory code.



To program a transmitter or card code you may enter the code manually using the keypad or you may scan the transmitter/card code.

**STEP 8** To scan a card code, press the **S** key and activate the card as shown in **fig a.**

To scan a transmitter code, press the **S** key and activate the transmitter as shown in **fig b.**

Touch the card to the card reader to activate remote device Model ECR-485B

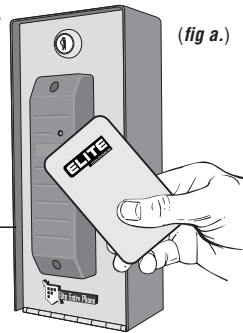

Processor

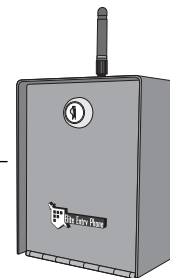

STAND-ALONE RECEIVER Model ERRB 485



Press button on transmitter to activate remote device

**STEP 9** Repeat steps 7 and 8 for up to ten devices per directory code. After the last device has been programmed, press **EXIT** or **ENTER** key to return to the program selection screen.

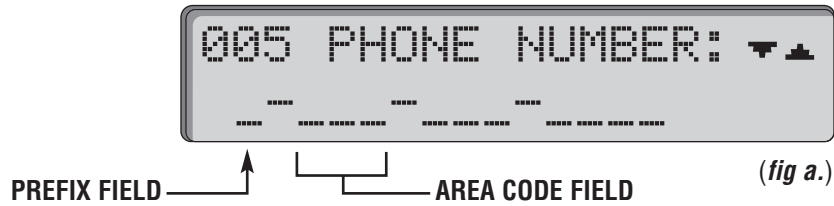

**NOTE:** The time zones and restrictions associated with transmitter/card codes can only be programmed remotely using the EMS modem software.

# AREA CODES



In special applications, it is necessary to enter area codes for Resident Phone Numbers. Area codes are entered from the Phone Number screen (*fig a.*).



Use the  key to enter the area code and prefix field (*fig b.*). The Prefix defaults to "1" for normal 11-digit dialing. Where necessary, you can change the prefix to any number. To choose 8, 9, or 10-digit dialing, when no prefix is needed, press  while in the prefix field. Then type the required number of digits in the area code field followed by the phone number. Press the  key to continue with the entry as described in the "Resident Information" section.

To erase "**Resident**" information, press the  key. Press the  key for assistance.

**IMPORTANT NOTE:** While in the help screens, programming will be disabled.

To continue programming, press the  button to exit the help screens first.

# UTILITY CODES

A 4-digit Utility Code (numeric characters only) may be assigned to “Utility Companies” such as delivery, telephone, construction companies, water, power, etc. These utilities can use their individual code to access the premises within the time zone that you program. Each system, no matter what the memory capacity, is equipped with 60 available Utility Codes and time zones.

**STEP 1** In the Program Selection Screen (*fig a.*), Press the **U** key. The screen will display (*fig b.*):



**STEP 2** You now have two options:



To program a new Utility Code, press the **N** key and type in a 4 digit code. If the code entered is used, type in another.

OR

Use the **↑** **↓** keys to view or edit existing Codes. The last screen will display memory spaces available. Select a code that you wish to edit.

**STEP 3** Press the **↓** key or the **ENTER** key to enter code. Type the name of the utility in the screen that follows and press the **↓** key or **ENTER** (*fig c.*).



**STEP 4** Enter the desired time zone in the screen that follows (*fig d.*) Use the **←** **↑** **↓** **→** keys to move the cursor. To view the previous screen, use the **▲** key. Press the **ENTER** key to complete your transaction.



For “User Mode” operation, Refer to the “Resident Use” Section.

To erase “Utility” information, press the **ERASE** key. Press the **HELP** key for assistance.

**IMPORTANT NOTE:** While in the help screens, programming will be disabled.

To continue programming, press the **EXIT** button to exit the help screens first.

# PASSWORD

***The factory present password is 7777. We suggest that you customize it.***

In the Program Selection Screen (*fig a.*), Press the **P** key.



(*fig a.*)

To customize a password, type in a four character password (it may be alphanumeric characters). Press the **ENTER** key to enter the new password. It will be displayed by asterisk (\*) for security (*fig b.*) (To leave the password unchanged, press the **EXIT** key.)



(*fig b.*)

A confirmation screen will appear (*fig c.*). Type in the same password and press the **ENTER** key. If you enter a different password, the password will not be confirmed and you will have to repeat the transaction.



(*fig c.*)

***Always remember your password! This password is required to enter the Program Mode. If you lose your password, you will need to contact the manufacturer to reissue a new password.***

Pressing the **HELP** button will provide users with a help message.

**IMPORTANT NOTE:** While in the help screens, programming will be disabled.

To continue programming, press the **EXIT** button to exit the help screens first.



# CLOCK/TIMER

The Clock/Timer allows you to set the date and time, and to program gates and doors to be opened or closed whenever specified. This clock is equipped with 100 year calender, auto leap year compensation and daylight savings.

In the Program Selection Screen (*fig a.*), Press the **C** key.

```
SELECT PROG MODE: ↓ ↑
(C)Clock/Timer
```

(*fig a.*)

Use the **↑** **↓** keys to scroll between the three different menu choices (*fig b.*). Select the number of your choice or press the **ENTER** key while on the selection of your choice.

```
PROG CLOCK/TIMER ↓
(1)Date & Time
```

```
PROG CLOCK/TIMER ↓ ↑
(2)Gate Timer
```

```
PROG CLOCK/TIMER ↑
(3)Door Timer
```

(*fig b.*)

**CAUTION:** Make sure to set the Date and Time before programming the clock timers for the door and gate.

## 1. DATE AND TIME

Use the **1** key to set the Date and time, use the **←** **↑** **↓** **→** keys to move the cursor. Press the **ENTER** key to enter your input. (*fig c.*)

```
DATE>02-11-2000
Time>07:31am p=pm
```

(*fig c.*)

Use the **↑** **↓** keys to select the current day of the week. Press the **ENTER** key to enter your input. (*fig d.*)

```
Today Is THURSDAY ▼ ▲
Use ↓ ↑ To Select Day
```

(*fig d.*)

Select daylight savings by pressing **Y** for yes or **N** for no. The **ENTER** key will complete the date and time entry. (*fig e.*)

```
Daylight Savings>y ▲
(Y)Yes (N)No
```

(*fig e.*)

# CLOCK/TIMER CONTINUED

## 2./3. DOOR AND GATE TIMERS

Press **2** to program *Gate* Timers Menu. Press **3** to program the *Door* Timers Menu.

```
Setup New Timers> N
View/Edit Timers> ↓↑
```

← See next page for instructions

← USE ARROWS TO VIEW / PROGRAM INDIVIDUAL TIME ZONES

Use **↑** **↓** to view and program timer(s) for Sunday through Saturday. Move the cursor **←** **→** **↶** **↷** to time and type in the setting. Two timers can be set for each day of the week following the procedure below. (fig a.)

```
SUN G Tmr-1: ON F=off ▼
07:00am -> 05:00pm ↓↑
...
SAT G Tmr-1: ON F=off ▼
07:00am -> 05:00pm ↓↑
```

(fig a.)

Program timers 1 and 2 for any day of the week (fig b. & c.)

Press **N** to turn timer 1 **ON** or press **F** to turn timer 1 **OFF**. Press the **ENTER** key. Type the desired timer 1 setting. For **am** type **A** For **pm** type **P** Press **ENTER** to program the timer 2.

```
SUN G Tmr-1: ON F=off ▼
07:00am -> 05:00pm ↓↑
```

(fig b.)

```
SUN G Tmr-2: ON F=off ▼
07:00am -> 05:00pm ↓↑
```

(fig c.)

To program the second timer, repeat the above procedure. Press the **ENTER** key when complete.

To exit "**Timers**" screen, press the **EXIT** key. Press the **HELP** key for assistance.

**IMPORTANT NOTE:** While in the help screens, programming will be disabled.

To continue programming, press the **EXIT** button to exit the help screens first.

# CLOCK/TIMER CONTINUED

## 2./3. DOOR AND GATE TIMERS, continued'

Press **2** to program *Gate* Timer Menu Press **3** to program the *Door* Timers Menu

```
Setup New Timers> N
View/Edit Timers> ↓↑
```

← **PRESS N TO PROGRAM SETS OF TIME ZONES**

← See previous page for instructions

Program timers 1 and 2 for any day of the week (*fig d.*)

Press **N** to turn timer 1 ON or press **F** to turn timer 1 OFF. Press the **ENTER** key. Type the desired timer 1 setting. For **am** type **A**, For **pm** type **P**. Press **ENTER** to program the timer 2.

```
GATE Tmr-1: ON F=off ▼
__ : __am -> __ : __pm
```

(*fig d.*)

To program the second timer, repeat the above procedure. Press the **ENTER** key when complete.

```
GATE Tmr-2: ON F=off ▼
__ : __am -> __ : __pm
```

Timer 1 & 2 settings can be copied to any day(s) of the week. Select the day(s) of the week to be copied. Press **Y** to select day or press **N** to not select day of week. Press **ENTER** when complete.

(*fig e.*)

```
COPY Timers1,2 To ▼▲
Workdays(y) Sun(n)
```

```
COPY Timers1,2 To ▼▲
Mon(n) Tue(n) Wed(n)
```

```
COPY Timers1,2 To ▲
Thr(n) Fri(n) Sat(n)
```

(*fig e.*)

To exit "**Timers**" screen, press the **EXIT** key. Press the **HELP** key for assistance.

**IMPORTANT NOTE:** While in the help screens, programming will be disabled.

To continue programming, press the **EXIT** button to exit the help screens first.

# STRIKE TIME

Strike Time sets the amount of time your gate or door relay will be held open.

In the Program Selection Screen (*fig a.*), Press the **S** key.

```
SELECT PROG MODE: ↓↑
(S)Strike Time
```

 (*fig a.*)

The strike time can be set for both gates and doors (*fig b.*)

```
Door Strike Time > D
Gate Strike Time > G
```

 (*fig b.*)

Press the **D** key to set the *Door Strike Time*. Type in a time from 1 to 99 seconds (*fig c.*). Press the **ENTER** key to enter your selection.

```
DOOR STRIKE TIME: ▼
[01-99] 10 Seconds
```

 (*fig c.*)

```
DOOR NAME/LOCATION ▲
South Entry Door
```

 (*fig e.*)

Press the **G** key to set the *Gate Strike Time*. Type in a time from 1 to 12 seconds (*fig d.*). Press the **ENTER** key to enter your selection.

```
GATE STRIKE TIME: ▼
[01-12] 05 Seconds
```

 (*fig d.*)

```
GATE NAME/LOCATION ▲
North Side Gate
```

 (*fig f.*)

For either the Gate or Door Strike Time, you may now type in a name and location (up to 13 characters) to which you want the programmed strike time applied. (*fig e.*) and (*fig f.*) Press the **ENTER** key to complete the transaction.

# TALK TIME

You can set the amount of time to talk on the Entry Phone at 20, 40, or 80 seconds.

```
SELECT PROG MODE: ↓↑
(T)Talk Time
```

 (*fig g.*)

```
TALKTIME IS 20 SEC
(B)40 Sec (C)80 Sec
```

 (*fig h.*)

In the Program Selection Screen (*fig g.*), Press the **T** key. Choose the desired Talk Time, press **A** for 20 seconds, **B** for 40 seconds, or **C** for 80 seconds (*fig h.*). Press the **ENTER** key to confirm your entry.

# GREETINGS

Use the Greeting Screen to customize the Welcome message.

In the Program Selection Screen (*fig a.*), Press the **G** key.



(*fig a.*)

Type the name of the facility and press the **ENTER** key to complete your entry. The system will automatically center your entry on the Welcome screen. (*fig b.*)



(*fig b.*)

# VOLUME ADJUST

Use the Speaker Volume Screen to adjust both voice message and speakerphone volume levels.

In the Program Selection Screen (*fig c.*), Press the **V** key.



(*fig c.*)

Use the **↑** **↓** keys to adjust the volume to the desired level (*fig d.*). Press the **ENTER** key to complete the entry.



(*fig d.*)

Pressing the **HELP** button will provide users with a help message.

**IMPORTANT NOTE:** While in the help screens, programming will be disabled. To continue programming, press the **EXIT** button to exit the help screens first.

# BACK-UP MEMORY

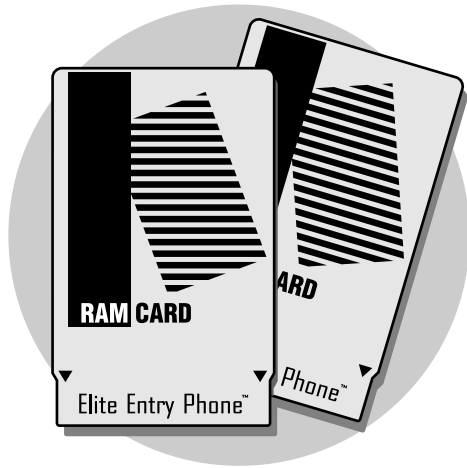

In the Program Selection Screen (*fig b.*),  
Press the **(B)** key.

Insert additional memory card in the  
Backup Slot.

**NOTE:** Back-up Memory card must be  
the same size or greater than the Main  
Memory card being backed up.

The screens will display when the cards  
were last updated. (*fig c.*) and (*fig d.*)  
Use the **(↑)** **(↓)** keys to scroll  
through the information.

Press the **(ENTER)** key to Backup.  
Press the **(EXIT)** key to exit the backup  
process (*fig e.*).

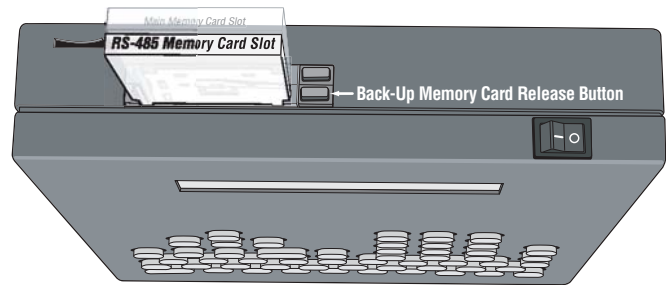

(*fig a.*)

**NOTE:** You must have an extra memory card (sold separately)  
installed in the RS 485 Slot (*fig a.*) of the Processor in order  
to perform the backup process.

```
SELECT PROG MODE: ↑
(U)Volume (B)Backup
```

(*fig b.*)

```
MAIN Card Updated On
05-15-01 03:50am ↓
```

(*fig c.*)

```
BACKUP Card Updated
02-11-01 04:20am ↓↑
```

(*fig d.*)

```
(ENTER) To Backup
(EXIT) To Quit
```

(*fig e.*)

Pressing the **(HELP)** button will provide users with a help message.

**IMPORTANT NOTE:** While in the help screens, programming will be disabled.  
To continue programming, press the **(EXIT)** button to exit the help screens first.

# ERROR MESSAGES

**OUT OF RANGE CODES:** If the processor detects one or more 3-digit codes present on the memory card inserted that cannot be accessed, an error message is displayed. (*fig a.*) Codes that cannot be accessed by the limitation of the system being used cannot be edited.



Codes Detected out  
of Range, See Manual

(*fig a.*)

**LOW BATTERY** If the battery backup is reaching it's minimal charge level, a battery icon with a "**B**" next to it will display in the top right corner of the display. (*fig b.*) An alert beep will accompany this icon. The batteries must be charged to continue.\*



Welcome To [Battery Icon] B  
Elite Entry Phone

(*fig b.*)

If the battery backup level reaches it's minimal charge, an error message will display (*fig c.*) and the system will become non-functional until the battery backup is charged by using the plug in transformer.\*



Battery Is Low  
It Must Be Recharged

(*fig c.*)

**LOW BATTERY ICONS:** If a battery icon appears in the top right corner of the display and the letter next to it is an "**M**" or a "**C**", as shown in (*fig d.*) and (*fig e.*), contact Manufacturer for instructions.



Welcome To [Battery Icon] C  
Elite Entry Phone

(*fig d.*)

**949-580-1700**



Welcome To [Battery Icon] M  
Elite Entry Phone

(*fig e.*)

**\*IMPORTANT NOTE:** In order to charge the battery in the Dial Code System, the processor **MUST** be plugged in to the transformer and the processor **MUST BE ON**. If the power is off on the processor, the battery will not be charging.



# LC ILLUSTRATION & PARTS LIST

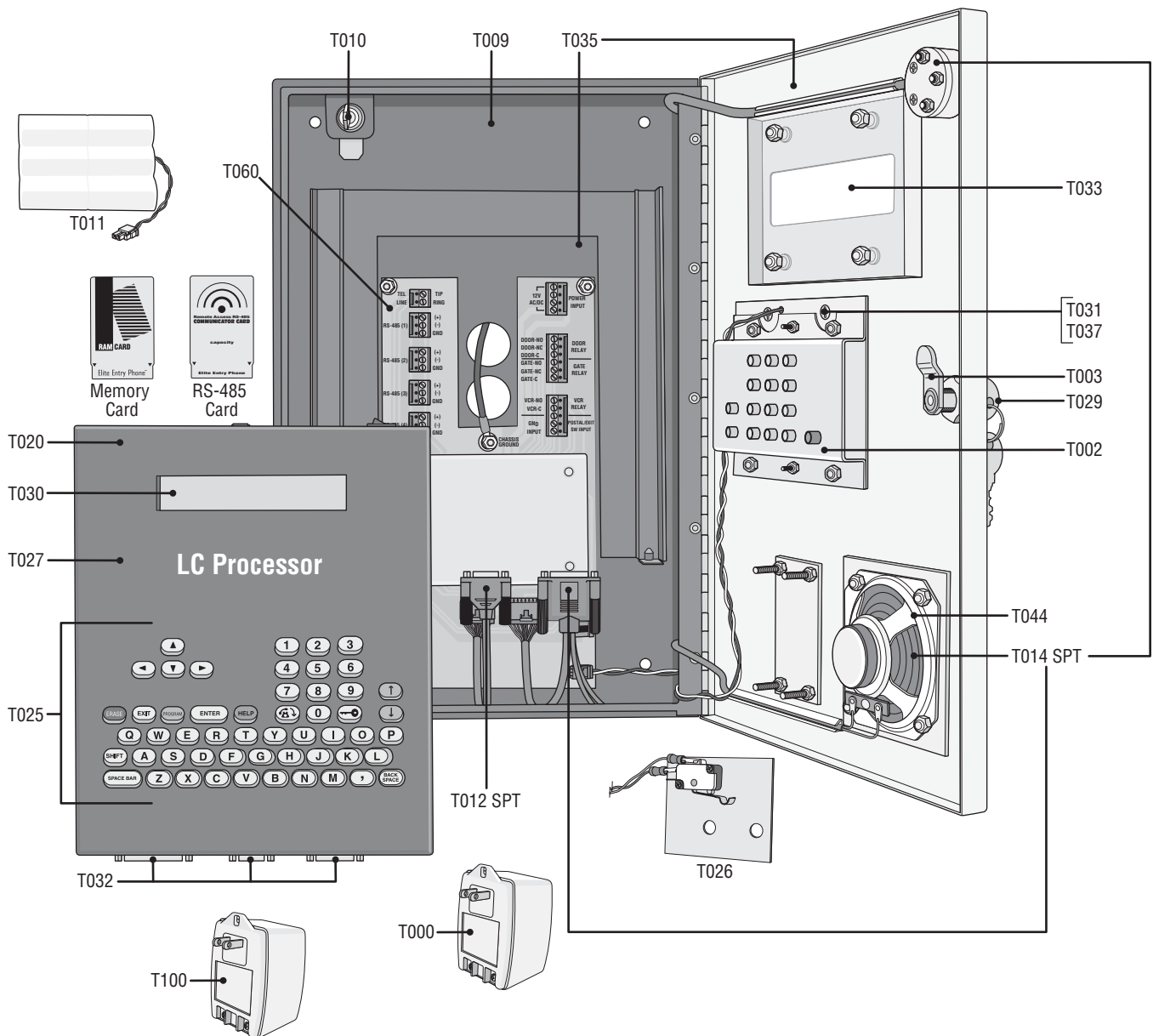

<u>LC Part #</u>	<u>LC Description</u>	<u>LC Part #</u>	<u>LC Description</u>
<b>T000</b>	Transformer 12 VAC 50VA (Provided)	<b>T033</b>	LCD Display Window
<b>T002</b>	External Keypad	<b>T035</b>	LC External Box Assembly
<b>T003</b>	Keylock	<b>T036</b>	Heater Pad Option (Pre-Installed in Processor)
<b>T009</b>	Processor Containment Box (Back Box)	<b>T037</b>	Keypad Light
<b>T010</b>	Processor Key Release / Lock	<b>T044</b>	Speaker 4 OHM
<b>T011</b>	Battery Back-Up	<b>T060</b>	Dial Code Surge Protection Board
<b>T012 SPT</b>	9-Pin Comm Port Connector (Surge Protection Terminal)	<b>T100</b>	16.5 VAC 50 VA Transformer (Optional)
<b>T014 SPT</b>	External Box Connection Kit (Surge Protection Terminal)	<b>T 25 MEM</b>	25 Name Memory Card
<b>T020</b>	LC Complete Internal Metal Box (Processor Box)	<b>T 50 MEM</b>	50 Name Memory Card
<b>T025</b>	Programming Keys	<b>T 150 MEM</b>	150 Name Memory Card
<b>T026</b>	Postal Lock Assembly	<b>T 250 MEM</b>	250 Name Memory Card
<b>T027</b>	LCD Processor - No Memory Card	<b>T 500 MEM</b>	500 Name Memory Card
<b>T029</b>	Key for Internal / External Lock	<b>T 1000 MEM</b>	1000 Name Memory Card
<b>T030</b>	LCD Display	<b>T RF CARD 4K</b>	RS-485 Communicator Card 4000
<b>T031</b>	Kit for Keypad Light	<b>T RF CARD 8K</b>	RS-485 Communicator Card 8000
<b>T032</b>	Phone Control Board (Inside Processor)	<b>T RF CARD 16K</b>	RS-485 Communicator Card 16000

All components and specifications are subject to change without notice.

# VF ILLUSTRATION & PARTS LIST

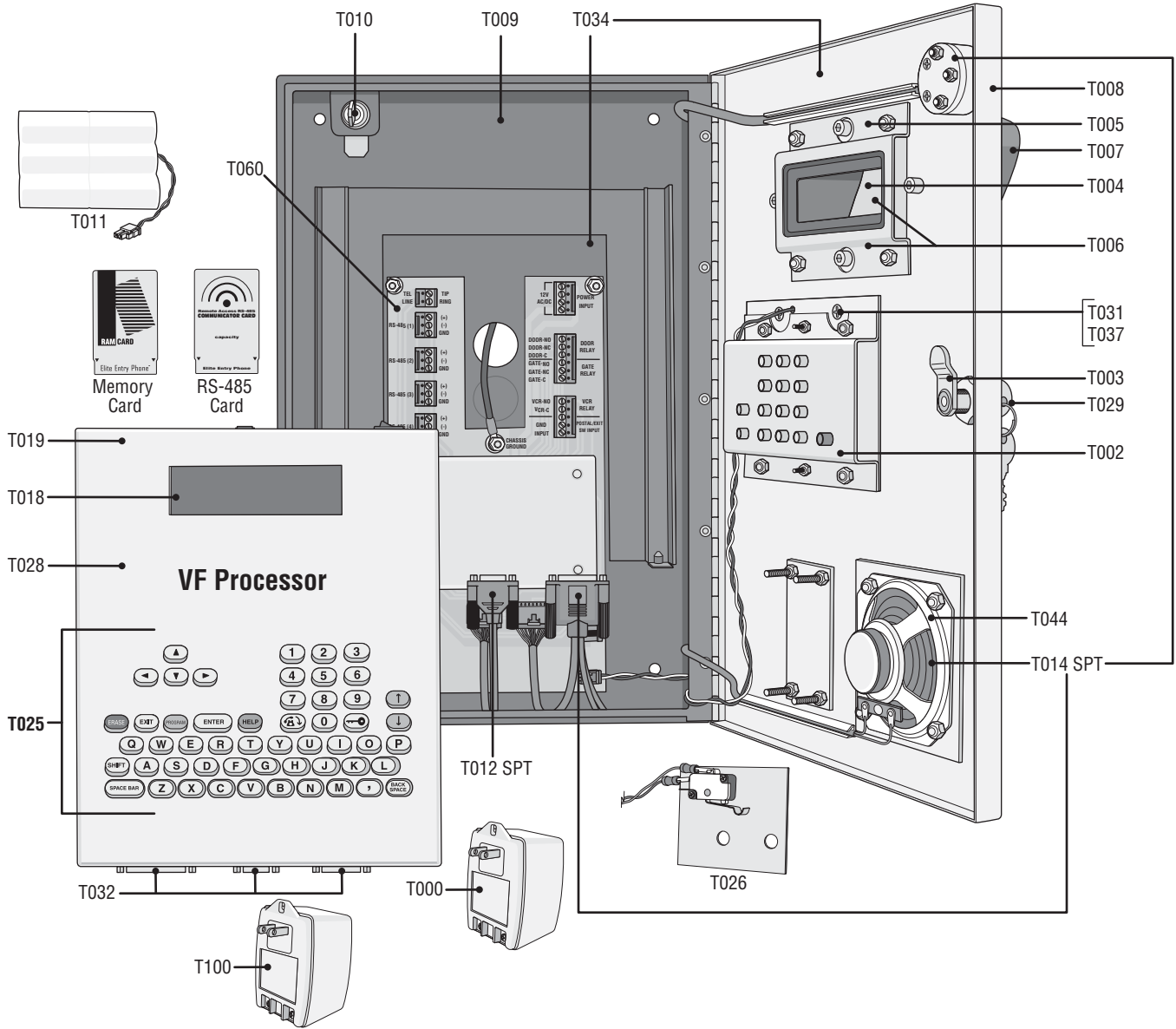

<u>VF Part #</u>	<u>VF Description</u>	<u>VF Part #</u>	<u>VF Description</u>
<b>T000</b>	Transformer 12 VAC 50VA (Provided)	<b>T029</b>	Key for Internal / External Lock
<b>T002</b>	External Keypad	<b>T031</b>	Kit for Keypad Light
<b>T003</b>	Keylock	<b>T032</b>	Phone Control Board (Inside Processor)
<b>T004</b>	Display Window Glass Only (VF)	<b>T034</b>	VF External Box Assembly
<b>T005</b>	Display Window Metal Bracket (VF)	<b>T036</b>	Heater Pad Option (Pre-Installed in Processor)
<b>T006</b>	Display Window Glass and Bracket (VF)	<b>T037</b>	Keypad Light
<b>T007</b>	Display Hood (VF)	<b>T044</b>	Speaker 4 OHM
<b>T008</b>	Stainless Steel Door (VF)	<b>T060</b>	Dial Code Surge Protection Board
<b>T009</b>	Processor Containment Box (Back Box)	<b>T100</b>	16.5 VAC 50 VA Transformer (Optional)
<b>T010</b>	Processor Key Release / Lock	<b>T 25 MEM</b>	25 Name Memory Card
<b>T011</b>	Battery Back-Up	<b>T 50 MEM</b>	50 Name Memory Card
<b>T012 SPT</b>	9-Pin Comm Port Connector (Surge Protection Terminal)	<b>T 150 MEM</b>	150 Name Memory Card
<b>T014 SPT</b>	External Box Connection Kit (Surge Protection Terminal)	<b>T 250 MEM</b>	250 Name Memory Card
<b>T018</b>	Vacuum Florescent Display	<b>T 500 MEM</b>	500 Name Memory Card
<b>T019</b>	VF Complete Internal Metal Box (Processor Box)	<b>T 1000 MEM</b>	1000 Name Memory Card
<b>T025</b>	Programming Keys	<b>T RF CARD 4K</b>	RS-485 Communicator Card 4000
<b>T026</b>	Postal Lock Assembly	<b>T RF CARD 8K</b>	RS-485 Communicator Card 8000
<b>T028</b>	VFD Processor - No Memory Card	<b>T RF CARD 16K</b>	RS-485 Communicator Card 16000

All components and specifications are subject to change without notice.

# APPROVALS

Elite Entry Phone Inc.

Complies with Part 68, FCC Rules



FCC Part 15 - Tested to comply with  
FCC standards for home or office use

This Class B digital apparatus meets all requirements of  
CANADIAN Interference Causing Equipment Regulations.



UL STD 294, 5th Ed.  
UL STD 1950, 3rd Ed.

## Instruction to the User:

This equipment has been tested and found to comply with the limits for a class 13 digital device, pursuant to part 15 of the FCC Rules. These limits are designed to provide reasonable protection against harmful interference in a residential installation. This equipment generates, uses and can radiate radio frequency energy and if not installed and used in accordance with the instructions, may cause harmful interference to radio communications. However, there is no guarantee that interference will not occur in a particular installation. If this equipment does cause harmful interference to radio or television reception, which can be determined by turning the equipment off and on, the user is encouraged to try to correct the interference by one or more of the following measures:

- \* Reorient or relocate the receiving antenna.
- \* Increase the separation between the equipment and receiver.
- \* Connect the equipment into an outlet on a circuit different from that to which the receiver is connected.
- \* Consult the dealer or an experienced radio/TV technician for help.

In order to maintain compliance with FCC regulations, shielded cables must be used with this equipment. Operation with non-approved equipment or unshielded cables is likely to result in interference to radio and TV reception. The user is cautioned that changes and modifications made to the equipment without the approval of manufacturer could void the users authority to operate this equipment.

**"Notice:** The Industry Canada (IC) label identifies certified equipment. This certification means that the equipment meets telecommunications network protective, operational and safety requirements as prescribed in the appropriate Terminal Equipment Technical Requirements document(s). The department does not guarantee the equipment will operate to the users satisfaction.

Before installing this equipment, users should ensure that it is permissible to be connected to the facilities of the local telecommunications company. The equipment must also be installed using a acceptable method of connection. The customer should be aware that compliance with the above conditions may not prevent degradation of service in some situations.

Repairs to certified equipment should be coordinated by a representative designated by the supplier. Any repairs or alterations made by a user to this equipment, or equipment malfunctions, may give the telephone communications company cause to request the user to disconnect the equipment.

User should ensure for their own protection, that the electrical ground connections of the power utility, telephone lines and internal metallic water pipe system, if present, are connected together. This precaution may be particularly important in rural areas."

**Caution:** Users should not attempt to make such connection themselves, but should contact the appropriate electric inspection authority, or an electrician, as appropriate."

**"Notice: The Ringer Equivalent Number (REN)** assigned to each terminal device provides an indication of the maximum number of terminals allowed to be connected to the telephone interface. The termination on a interface may consist of any combination of devices subject only to the requirement that the sum of the Ringer Equivalent Numbers of all the devices does not exceed 5."